

F

Reg. No. :

--	--	--	--	--	--	--	--	--	--	--

Question Paper Code : 91709

B.E./B.Tech. DEGREE EXAMINATION, NOV 2022

First Semester

Computer Science and Engineering

19UME109 – ENGINEERING GRAPHICS

(Common to EEE, IT, CHEMICAL, AGRI, BME)

(Regulation 2019)

Duration: Three hours

Maximum: 100 Marks

Answer ALL Questions

PART - A (5 x 20 = 100 Marks)

1. (a) A cylinder of base diameter 50mm and axis height 65mm is resting on HP on a point on the circumference of the base with its axis inclined at 50° to HP and parallel to VP. Draw its projections CO1-App (20)

Or

- (b) A square pyramid of base side 40 mm and axis length 70 mm is resting on HP on one of its base corner with its axis parallel to VP and inclined 50° to HP. Draw its projections. CO1-App (20)

2. (a) A triangular prism of 35 mm side of base and axis 60 mm long has its base on the ground and its rectangular face is parallel and nearer to VP. A section plane perpendicular to VP and inclined at 60° to HP and passing through a point on the axis 20 mm below from the top face. Draw the front view, sectional top view and the true shape of the section. CO2-App (20)

Or

- (b) A cone of base diameter 50 mm and axis height 60 mm is lying on the ground vertically. It is cut by a plane perpendicular to VP and inclined at 45° to HP and cuts the axis at a point 30 mm below the apex. Draw the front view, sectional top view and the true shape of the section. CO2-App (20)

3. (a) A rectangular pyramid, base 30 mm x 20 mm and 60 mm axial height is resting on its base in HP with shorter edge perpendicular to VP. It is cut by a section plane perpendicular to VP and 60° to HP at the midpoint of the axis. The top portion containing the vertex is removed. Draw the lateral surface development of the remaining portion. CO3-App (20)

Or

- (b) A right circular cone of base diameter 60 mm and height 70 mm is resting on its base on the ground. It is cut by a plane perpendicular to the VP and inclined at 30° to the HP. The cutting plane bisects the axis of the cone. Draw the development of the lateral surfaces of the truncated cone. CO3-App (20)

4. (a) A hexagonal prism, side of base 25 mm and height 50 mm rests on HP and one of the edges of its base is parallel to VP. A section plane perpendicular to VP and inclined at 45° to HP bisects the axis of the prism. Draw the isometric projection of the truncated prism. CO4-App (20)

Or

- (b) A cone of base diameter 50 mm and height 70 mm stands on HP with its base. It is cut by a cutting plane inclined at 30° to HP cutting the axis of the cone at a height of 35 mm from its base. Draw the isometric view of the truncated cone. CO4-App (20)

5. (a) The pictorial view of an object is shown in Fig.1. Using the first angle orthographic projection, draw its Elevation looking in the direction of arrow, Plan and Left side view. Dimension the views. CO5-App (20)

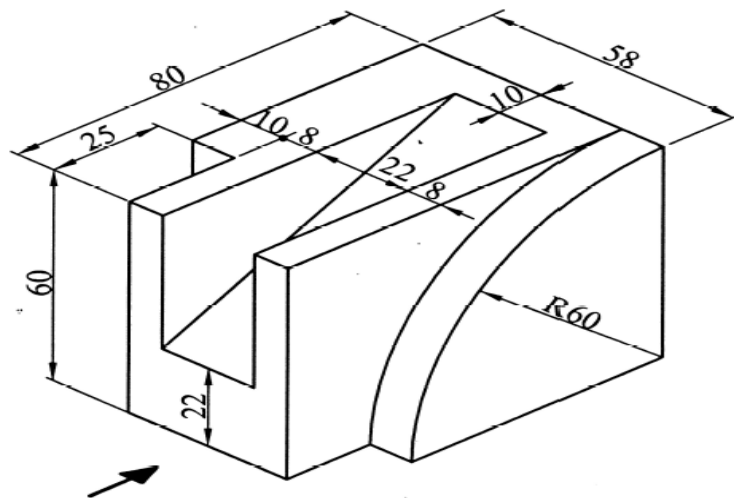
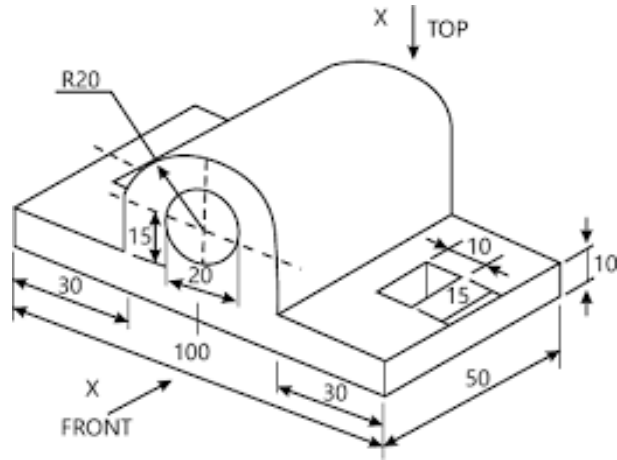

Fig. - 1

Or

(b) Draw the orthographic views for the given diagram using free hand CO5-App (20)

(i) Front view (ii) Top view (iii) right side view



All dimensions are in 'mm'

