

A

Reg. No. :

--	--	--	--	--	--	--	--	--	--

**Question Paper Code: 52309**

B.E. / B.Tech. DEGREE EXAMINATION, DEC 2021

Second Semester

Electrical and Electronics Engineering

15UEE209 - ELECTRIC CIRCUITS

(Regulation 2015)

Duration: Three hours

Maximum: 100 Marks

Answer ALL Questions

PART A - (10 x 1 = 10 Marks)

1. Which of the following is not a Active element? CO1- App  
(a) Voltage source      (b) Current source      (c) Generator      (d) Vacuum cleaner
2. Which of the following condition is satisfy by the Ohm's Law? CO1- R  
(a) Constant voltage      (b) Constant temperature  
(c) Constant current      (d) None of the above
3. Superposition theorem is only applicable for? CO2- R  
(a) Nonlinear system      (b) Linear system      (c) Both (a) & (b)      (d) None of the above
4. Maximum power transfer theorem is applicable for? CO2-U  
(a) Iron box      (b) Grinder      (c) Sound system      (d) Air conditioner
5. Antiresonance is also called as ? CO3- R  
(a) Parallel resonance      (b) Series resonance  
(c) Both (a) & (b)      (d) None of the above
6. Mutual inductance is ? CO3- R  
(a)  $K = M \sqrt{(L_1 L_2)}$       (b)  $M = K \sqrt{(L_1 L_2)}$       (c)  $M = C \sqrt{(L_1 L_2)}$       (d)  $M = K \sqrt{(L_1 L_2)}$
7. Rising time for overdamped system is ? CO4- R  
(a) 0 % to 100 %      (b) 0 % to 90 %      (c) 0 % to 63.2 %      (d) 0 % to 36.8 %

8. Time constant of RC circuit? CO4- R  
 (a) 0 % to 63.2 %      (b) 0 % to 36.8 %      (c) 2T      (d) 4T
9. Power factor is not defined as CO5- R  
 (a) Angle between voltage and current  
 (b) Ratio between Resistance / Impedance  
 (c) Real power / Apparent power  
 (d) Coil displacement
10. Time period is? CO5- R  
 (a)  $2\pi / \omega$       (b)  $F = 1 / T$   
 (c) Time taken for half cycle      (d) Time taken for half cycle

PART – B (5 x 2= 10 Marks)

11. What is current? CO1- R
12. State current division rule. CO2- R
13. Define coefficient of coupling. CO3- R
14. What is transient state? CO4-App
15. Define complex power. CO5-Ana

PART – C (5 x 16= 80 Marks)

16. (a) Determine the total resistance R of the given circuit? CO1- App (16)

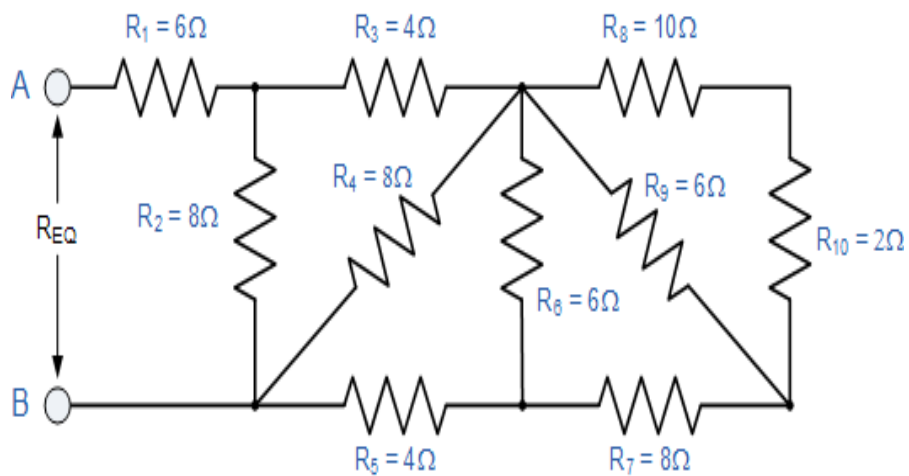

Or

- (b) Apply Kirchhoff's voltage law and find the current  $I_1$  and  $I_2$  and  $I_3$  flowing in the given circuit using Cramer rule? CO1- App (16)

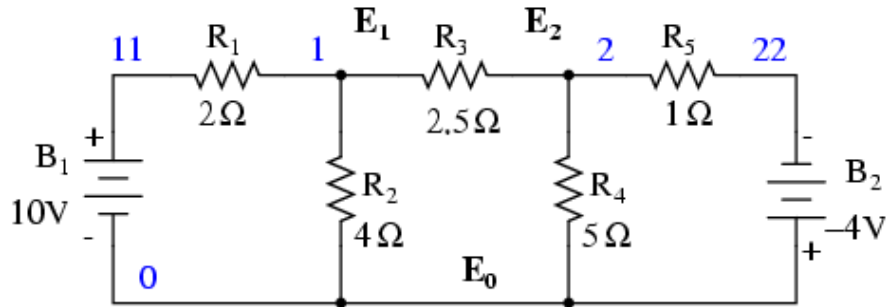

17. (a) Using Thevenin's theorem, solve this problem and find the current flow through between Terminal A and Terminal B. CO2- U (16)

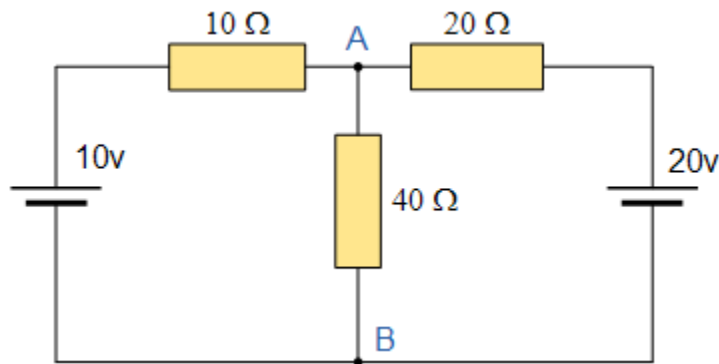

Or

- (b) Explain maximum power transfer theorem and derive the expression for maximum power transfer. CO2- U (16)
18. (a) The parameter of a RLC parallel circuit excited by a current source are  $R = 40 \text{ Ohm}$ ,  $L = 2 \text{ mH}$ ,  $C = 3 \text{ Microfarad}$ . Determine the CO3- Ana (16)
- (i) Resonant frequency
  - (ii) Quality factor
  - (iii) Bandwidth
  - (iv) Cut – off frequencies.

Or

- (b) Two coupled coils with  $L_1 = 0.02 \text{ H}$ ,  $L_2 = 0.01 \text{ H}$  and  $K = 0.5$  are connected in our different ways, series Aiding, series opposing and Parallel Aiding and Parallel Opposition of the winding sense. What are the four equivalent inductances? CO3- Ana (16)
19. (a) A sinusoidal voltage of  $10 \sin 100 t$  is connected in series with a switch and  $R = 10 \text{ Ohm}$ ,  $L = 0.1 \text{ H}$ . If the switch is closed at  $t = 0$ , determine the transient current  $i(t)$ . CO4- U (16)
- Or
- (b) In the series R, L circuit resistance is  $50 \text{ Ohm}$ , and Inductance is  $0.5 \text{ H}$  and applied voltage is  $e = 100 e^{-50 t}$ . Find the CO4- U (16)
- (i) Resulting current
- (ii) Initial rate of change of current
20. (a) Explain the power and power factor measurements in three phase circuits. CO5- U (16)
- Or
- (b) (i) Mention some advantages of three Phase system over a Single Phase system? CO5- U (8)
- (ii) Compare balanced network and unbalanced network CO5- U (8)