

Reg. No. :

--	--	--	--	--	--	--	--	--	--

Question Paper Code: 35302

B.E. / B.Tech DEGREE EXAMINATION, DEC 2021

Fifth Semester

Electrical and Electronics Engineering

01UEE502 - CONTROL SYSTEMS

(Regulation 2013)

Duration: Three hours

Maximum: 100 Marks

Answer ALL Questions

PART A - (10 x 2 = 20 Marks)

1. What are the basic properties of signal flow graph?
2. Define mathematical model of the system.
3. List the time domain specifications.
4. Why derivative controller is not used in control system?
5. What is phase and gain cross-over frequency?
6. Name the parameters which constitute the frequency domain specifications.
7. What is the necessary and sufficient condition for stability?
8. Derive the transfer function of a lead compensator network.
9. What are the properties of state transition matrix?
10. Define controllability.

PART - B (5 x 16 = 80 Marks)

11. (a) Obtain the closed loop transfer function $C(S) / R(S)$ by using Mason's Gain Formula. (16)

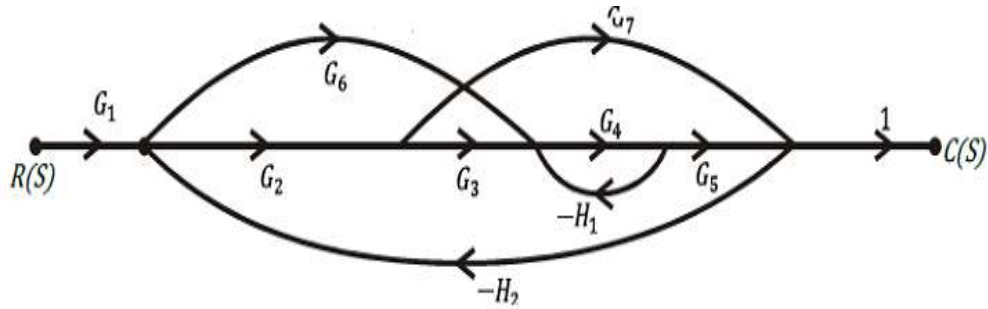

Or

- (b) Using block diagram reduction technique find the closed loop transfer function of the system whose block diagram is shown in figure. (16)

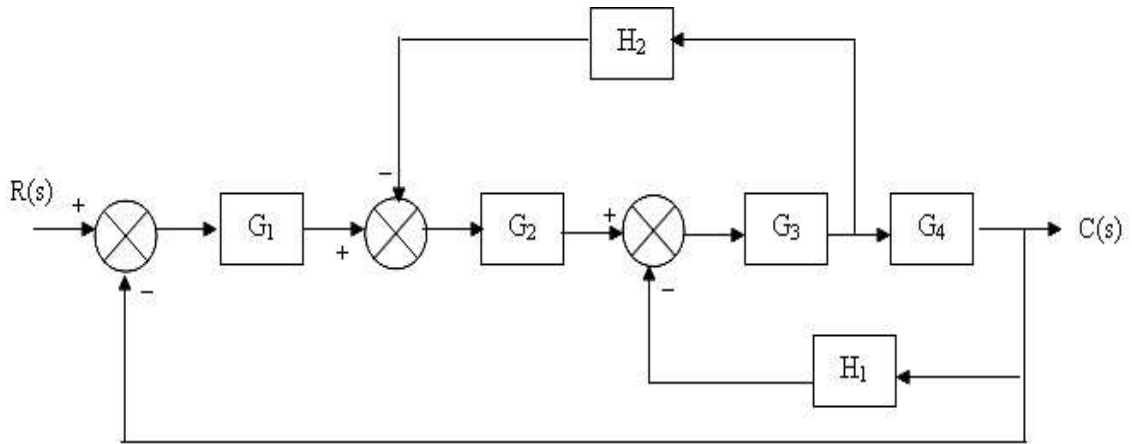

12. (a) Sketch the root locus of the system whose open loop transfer function is $G(S) = \frac{K}{s(s+2)(s+4)}$. Find the value of K so that the damping ratio of the closed loop system is 0.5. (16)

Or

- (b) The open loop transfer function of a unity feedback system is given by $G(s) = \frac{K(s+9)}{s(s^2+4s+11)}$. Sketch the root locus of the system. (16)

13. (a) Sketch Bode plot for the following transfer function and determine the gain and phase cross over frequencies.

$$G(s) = \frac{10}{s(1 + 0.4s)(1 + 0.1s)}. \quad (16)$$

Or

- (b) Consider a unity feedback system having an open loop transfer function

$$G(s) = \frac{K}{s(1 + 0.5s)(1 + 4s)}. \text{ Sketch the polar plot and determine the value of } K \text{ so that}$$

(i) gain margin is 20 db

(ii) phase margin is 30° . (16)

14. (a) Use the routh stability criterion to determine the location of roots on the s-plane and hence the stability for the system represented by the characteristic equation

$$s^5 + 4s^4 + 8s^3 + 8s^2 + 7s + 4 = 0. \quad (16)$$

Or

- (b) Determine the nyquist plot for the system whose open loop transfer function is,

$$G(s)H(s) = \frac{K}{s(s+2)(s+10)}. \text{ Determine the range of } K \text{ for which closed loop system is stable.} \quad (16)$$

15. (a) Determine the canonical state model of the system, whose transfer function is

$$T(s) = \frac{2(s+5)}{(s+2)(s+3)(s+4)}. \quad (16)$$

Or

(b) A linear time-invariant system is characterized by homogeneous state equation.

$$\begin{bmatrix} \dot{} \\ x_1 \\ \dot{} \\ x_2 \end{bmatrix} = \begin{bmatrix} 1 & 0 \\ 1 & 1 \end{bmatrix} \begin{bmatrix} x_1 \\ x_2 \end{bmatrix}. \text{ Compute the solution of the homogeneous equation, assuming}$$

the initial state vector, $x_0 = \begin{bmatrix} 1 \\ 0 \end{bmatrix}$. (16)