

Reg. No. :

--	--	--	--	--	--	--	--	--	--

Question Paper Code: 33504

B.E. / B.Tech. DEGREE EXAMINATION, DEC 2021

Third Semester

Electronics and Instrumentation Engineering

01UEI304 - ELECTRICAL CIRCUITS AND NETWORKS

(Common to Instrumentation and Control Engineering)

(Regulation 2013)

Duration: Three hours

Maximum: 100 Marks

Answer ALL Questions.

PART A - (10 x 2 = 20 Marks)

1. State Ohm's law.
2. State Kirchoff's current law and voltage law.
3. Each of the three arms of a delta connected network has a resistance of 3Ω . Formulate the equivalent star connected network.
4. Define Maximum power transfer theorem.
5. A series RLC circuit resonates at 1.5 kHz and consumes 50 W from a 50 V supply. The circuit has a bandwidth of 0.75 kHz . Calculate the values of R , L and C .
6. Define coefficient of coupling.
7. What is meant by transient response?
8. Infer transient response.
9. Compare three-phase star connected system with delta connected system.
10. Define power and power factor.

PART - B (5 x 16 = 80 Marks)

11. (a) (i) Using the node voltage analysis, find all the node voltages and currents in $1/3 \text{ ohm}$ and $1/5 \text{ ohm}$ resistances of figure. (10)

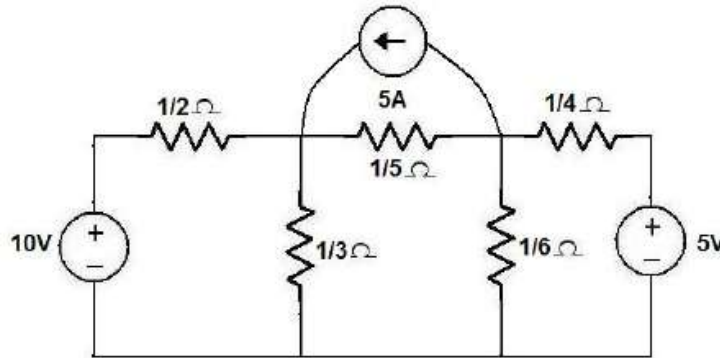

- (ii) Discuss about voltage and current division principles. (6)

Or

- (b) Using nodal voltage method, calculate the voltages of nodes 'm' and 'n' and currents through $j2\Omega$ and $-j2\Omega$ reactance in the network. (16)

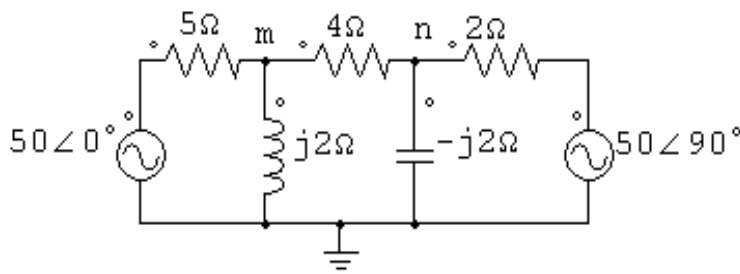

12. (a) Find Thevenin's equivalent circuit for the circuit shown below. (16)

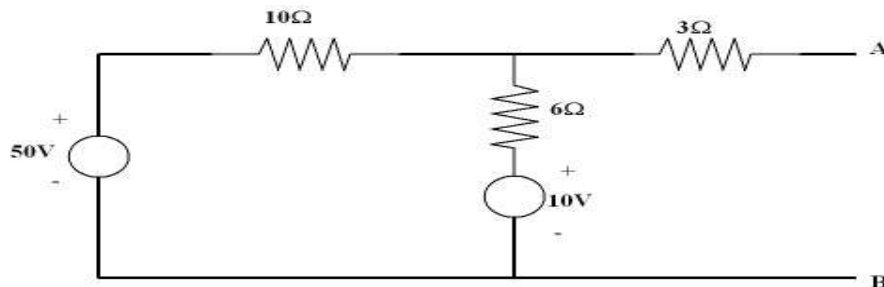

Or

- (b) (i) Find the value of R_L so that maximum power is delivered to the load resistance shown in figure. (8)

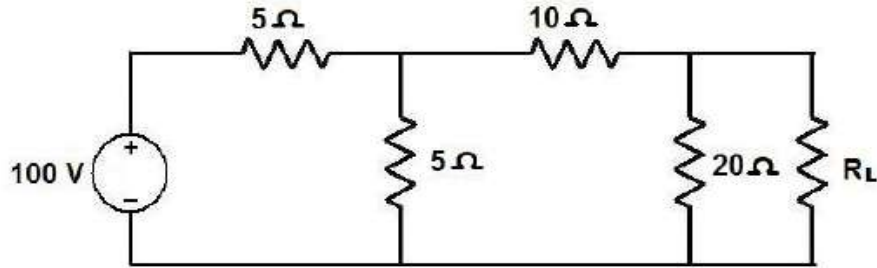

- (ii) State and explain reciprocity theorem. (8)

13. (a) Describe the condition for resonance in a series RLC circuit and derive an expression for resonant frequency and frequency at which voltage across capacitor is maximum. Also draw the resonance curve and explain the values for the following parameters at resonance (i) phase angle (ii) current (iii) impedance (iv) admittance and (v) power factor. (16)

Or

- (b) (i) For the given circuit constants, find (i) Mutual Inductance (ii) Find equivalent inductance for all the combination $L_1 = 0.02H$, $L_2 = 0.01H$ and $k = 0.5$. (8)
- (ii) Calculate the mutual inductance of two coils of self - inductances $100\mu H$ and $240\mu H$, which are connected in series to yield a total inductance of $146\mu H$. (8)

14. (a) A series RLC circuits has $R = 50 \text{ ohm}$, $L = 0.2H$, and $C = 50 \mu F$. Constant voltage of $100V$ is impressed upon the circuit at $t = 0$. Find the expression for the transient current assuming initially relaxed conditions. (16)

Or

- (b) Derive an expression for current response of RL and RC series circuit transients. (16)

15. (a) (i) Using phasor diagram, formulate the relationship between line current and phase current related to delta connected load. (8)
- (ii) A symmetrical 3 phase $400V$ system supplies a balanced delta connected load. The current in each branch circuit is $20A$ and phase angle 40° (lag). Calculate the line current, power factor and total power of the circuit. (8)

Or

- (b) (i) Explain about a balanced three phase system star connected load. (8)
- (ii) Explain about a unbalanced three phase system delta connected load. (8)