

Reg. No. :

--	--	--	--	--	--	--	--	--	--

Question Paper Code: 31701

B.E./B.Tech. DEGREE EXAMINATION, DEC 2021

First Semester

Civil Engineering

01UME107 – ENGINEERING GRAPHICS

(Common to ALL branches)

(Regulation 2013)

Duration: Three hours

Maximum: 100 Marks

Answer ALL Questions

PART - A (5 x 20 = 100 Marks)

1. (a) Sketch by free hand, the following views of the object shown in Figure 1. CO1- App (20)
- Figure 1.
- (i) The front view in the direction of the arrow.
 - (ii) The top view and
 - (iii) The available side view.

The dimensioning is also to be done by free hand .

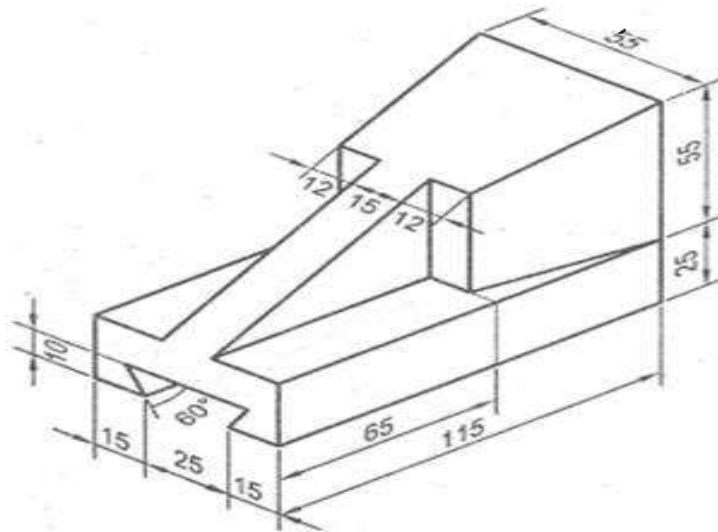
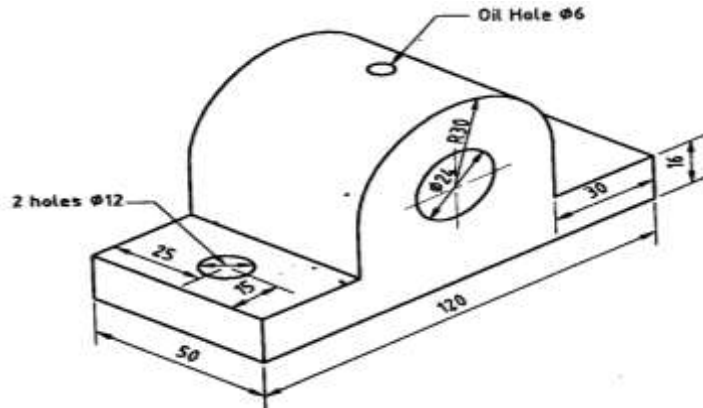

Figure 1 All dimensions are in 'mm'

Or

- (b) Draw the plan, elevation and left side view of the following object. CO1- App (20)
All dimensions are in mm.



2. (a) A line AB measuring 85 mm has its end 'A' is 25 mm above the HP and 20 mm in front of the VP. The front view and top view measure 70 mm and 55 mm respectively. Draw the projections of the line and determine its true inclinations. CO2- App (20)
- Or
- (b) One end A of a line AB , 80 mm long is 30 mm in front of VP and 20 mm above HP. The line is inclined at 30° to the HP and 45° to the VP. Draw the projections of the line. CO2- App (20)
3. (a) A cone of base diameter 60 mm and altitude 80 mm rests on the H.P. with its axis inclined at 30° to the H.P. and parallel to the V.P. Draw its front and top views by change of position method. CO3- App (20)
- Or
- (b) A hexagonal pyramid of base side 30 mm and axis length 60 mm is resting on V.P. one of its base edges with the face containing the resting edges perpendicular to both H.P. and V.P. Draw its projections. CO3- App (20)
4. (a) A hexagonal pyramid of base side 25 mm and height 50 mm rests on the HP on one of its ends with two base edges parallel to the VP. It is cut by a plane perpendicular to the VP and inclined at 45° to the HP at a distance of 20 mm from the vertex on the axis. Draw the front view, sectional top view and true shape of the section. CO4- App (20)

Or

(b) A cone of diameter 60 *mm* and height 70 *mm* is resting on its base on the ground. It is cut by a plane perpendicular to VP and parallel to HP at a distance 20 *mm* from the vertex. It is also cut by a plane inclined at 40° to the base and perpendicular to VP and meeting the axis at a point 20 *mm* from the base. Draw the development of the lateral surface of the remaining portion of the cone. CO4- App (20)

5. (a) A hexagonal prism of base side 25 mm and height 50 mm rests on the HP and one of the edges of its base is parallel to VP. A section plane perpendicular to VP and inclined at 50° to HP bisects the axis of the prism. Draw the isometric projection of the truncated prism, showing the cut surface. CO5- App (20)

Or

(b) A plate washer of diameter 60 *mm* and thickness 10 *mm* has hexagonal hole side 20 *mm* at its centre. Draw the isometric view of the washer, keeping the curved surface on HP. CO5- App (20)

