

A

Reg. No. :

--	--	--	--	--	--	--	--	--	--

Question Paper Code: 55703

B.E. / B.Tech. DEGREE EXAMINATION, MAY 2022

Fifth Semester

Mechanical Engineering

15UME503 - DESIGN OF MACHINE ELEMENTS

(Regulation 2015)

(Approved data book are permitted)

Duration: Three hours

Maximum: 100 Marks

Answer ALL Questions

PART A - (10 x 1 = 10 Marks)

1. The energy stored in a body when strained within elastic limit is known as CO1- R
(a) Resilience (b) Proof resilience (c) Strain energy (d) Impact energy
2. The bending stress in a curved beam is CO1- R
(a) Zero at the centroidal axis (b) Zero at the point other than centroidal axis
(c) Maximum at the neutral axis (d) None of the above
3. Two shafts *A* and *B* are made of the same material. The diameter of the shaft *A* CO2- R
is twice as that of shaft *B*. The power transmitted by the shaft *A* will be ____ of
shaft *B*.
(a) Twice (b) Four times (c) Eight times (d) Sixteen times
4. A key made from a cylindrical disc having segmental cross-section, is known as CO2- R
(a) Feather key (b) Gib head key (c) Woodruff key (d) Flat saddle key
5. In a steam engine, the piston rod is usually connected to the CO3- R
crosshead by means of a
(a) Knuckle joint (b) Universal joint (c) Cotter joint (d) Flange coupling
6. The centre to centre distance between two consecutive rivets in a row, is called CO3- R
(a) Margin (b) Pitch (c) Back pitch (d) Diagonal pitch

7. When helical compression spring is cut into halves, the stiffness of the resulting spring will be CO4- R
- (a) Same (b) Double (c) One-half (d) One-fourth
8. Due to the centrifugal force acting on the rim, the flywheel arms will be subjected to CO4- R
- (a) Tensile stress (b) Compressive stress (c) Shear stress (d) None of the above
9. In designing a connecting rod, it is considered like _____ for buckling about X -axis. CO5- R
- (a) Both ends fixed (b) Both ends hinged
- (c) One end fixed and the other end hinged (d) One end fixed and the other end free
10. When the length of the journal is equal to the diameter of the journal, then the bearing is said to be a CO5- R
- (a) Short bearing (b) Long bearing (c) Medium bearing (d) Square bearing

PART – B (5 x 2= 10Marks)

11. Distinguish clearly between direct stress and bending stress. CO1- U
12. What is the effect of keyway cut into the shaft? CO2- U
13. Enumerate the different types of riveted joints and rivets. CO3- U
14. Discuss the various types of stresses induced in a flywheel rim. CO4- U
15. What is the function of a connecting rod of an internal combustion engine? CO5- U

PART – C (5 x 16= 80Marks)

16. (a) A mild steel shaft of 50 mm diameter is subjected to a bending moment of 2000 N-m and a torque T . If the yield point of the steel in tension is 200 MPa, find the maximum value of this torque without causing yielding of the shaft according to 1.the maximum principal stress; 2. The maximum shear stress; and 3.the maximum distortion strain energy theory of yielding. CO1- App (16)

Or

- (b) A machine component is subjected to a flexural stress which fluctuates between $+ 300 \text{ MN/m}^2$ and $- 150 \text{ MN/m}^2$. Determine the value of minimum ultimate strength according to 1. Gerber relation; 2. Modified Goodman relation; and 3. Soderberg relation. Take yield strength = 0.55 Ultimate strength; Endurance strength = 0.5 Ultimate strength; and factor of safety = 2. CO1- App (16)

17. (a) A shaft is supported by two bearings placed 1 m apart. A 600 mm diameter pulley is mounted at a distance of 300 mm to the right of left hand bearing and this drives a pulley directly below it with the help of belt having maximum tension of 2.25 kN. Another pulley 400 mm diameter is placed 200 mm to the left of right hand bearing and is driven with the help of electric motor and belt, which is placed horizontally to the right. The angle of contact for both the pulleys is 180° and $\mu = 0.24$. Determine the suitable diameter for a solid shaft, allowing working stress of 63 MPa in tension and 42 MPa in shear for the material of shaft. Assume that the torque on one pulley is equal to that on the other pulley. CO2- App (16)

Or

- (b) Design and make a neat dimensioned sketch of a muff coupling which is used to connect two steel shafts transmitting 40 kW at 350 r.p.m. The material for the shafts and key is plain carbon steel for which allowable shear and crushing stresses may be taken as 40 MPa and 80 MPa respectively. The material for the muff is cast iron for which the allowable shear stress may be assumed as 15 MPa. CO2- App (16)
18. (a) Design a knuckle joint for a tie rod of a circular section to sustain a maximum pull of 70 kN. The ultimate strength of the material of the rod against tearing is 420 MPa. The ultimate tensile and shearing strength of the pin material are 510 MPa and 396 MPa respectively. Determine the tie rod section and pin section. Take factor of safety = 6. CO3- Ana (16)

Or

- (b) A welded joint as shown in Fig., is subjected to an eccentric load of 2 kN. Find the size of weld, if the maximum shear stress in the weld is 25 MPa. CO3- Ana (16)

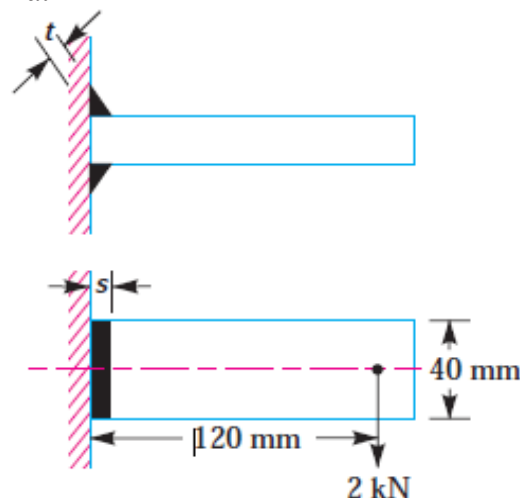

19. (a) A helical compression spring made of oil tempered carbon steel is subjected to a load which varies from 400 N to 1000 N. The spring index is 6 and the design factor of safety is 1.25. If the yield stress in shear is 770 MPa and endurance stress in shear is 350 MPa, find:
1. Size of the spring wire,
 2. Diameters of the spring,
 3. Number of turns of the spring
 4. Free length of the spring. The compression of the spring at the maximum load is 30 mm. The modulus of rigidity for the spring material may be taken as 80 kN/mm².

Or

- (b) A single cylinder double acting steam engine develops 150 kW at a mean speed of 80 r.p.m. The coefficient of fluctuation of energy is 0.1 and the fluctuation of speed is $\pm 2\%$ of mean speed. If the mean diameter of the flywheel rim is 2 metres and the hub and spokes provide 5 percent of the rotational inertia of the wheel, find the mass of the flywheel and cross-sectional area of the rim. Assume the density of the flywheel material (which is cast iron) as 7200 kg / m³.
20. (a) Design a journal bearing for a centrifugal pump from the following data: Load on the journal = 20000 N; Speed of the journal = 900 r.p.m.; Type of oil is SAE 10, for which the absolute viscosity at 55°C = 0.017 kg / m-s; Ambient temperature of oil = 15.5°C; Maximum bearing pressure for the pump = 1.5 N / mm². Calculate also mass of the lubricating oil required for artificial cooling, if rise of temperature of oil be limited to 10°C. Heat dissipation coefficient = 1232 W/m²/°C.

Or

- (b) Design a connecting rod for an I.C. engine running at 1800 r.p.m. and developing a maximum pressure of 3.15 N/mm². The diameter of the piston is 100 mm; mass of the reciprocating parts per cylinder 2.25 kg; length of connecting rod 380 mm; stroke of piston 190 mm and compression ratio 6: 1. Take a factor of safety of 6 for the design. Take length to diameter ratio for big end bearing as 1.3 and small end bearing as 2 and the corresponding bearing pressures as 10 N/mm² and 15 N/mm². The density of material of the rod may be taken as 8000 kg/m³ and the allowable stress in the bolts as 60 N/mm² and in cap as 80 N/mm². The rod is to be of I-section for which you can choose your own proportions. Draw a neat dimensioned sketch showing provision for lubrication. Use Rankine formula for which the numerator constant may be taken as 320 N/mm² and the denominator constant 1 / 7500.