

**F**

Reg. No. :

--	--	--	--	--	--	--	--	--	--	--

**Question Paper Code:51708**

B.E./B.Tech. DEGREE EXAMINATION, MAY 2022

First Semester

Civil Engineering

15UME108 – ENGINEERING GRAPHICS

(Common to ALL branches)

(Regulation 2015)

Duration: Three hours

Maximum: 100 Marks

Answer ALL Questions

PART - A (5 x 20 = 100 Marks)

1. (a) A circle of 50 mm diameter rolls on a straight line without slipping. Trace the locus of a point 'P' on the circumference of the circle rolling for one revolution. Name the curve. Draw normal and tangent to the curve at any point on the curve. CO1-App (20)  
Trace the locus of a point 'P' on the circumference of the circle rolling for one revolution. Name the curve. Draw normal and tangent to the curve at any point on the curve.  
Or
- (b) The end A of a line AB is 10 mm in front of VP and 20 mm above HP. The line is inclined at  $30^{\circ}$  to HP and front view is  $45^{\circ}$  with XY. Top view is 60 mm long. Draw the projections. Find the true length and inclinations with VP. Locate the traces. CO1-App (20)
2. (a) A hexagonal pyramid of base side 30 mm and axis length 60 mm is resting on HP on one of its base corners with its axis inclined at  $35^{\circ}$  to HP. The base sides containing the resting corner are equally inclined to HP. Draw its projections. CO2-App (20)
- Or
- (b) A cone of base diameter 50 mm and axis length 60 mm is resting on HP on a point on the circumference of the base. Its base is inclined at  $50^{\circ}$  to HP and perpendicular to VP. Draw its projections. CO2-App (20)

3. (a) Draw the development of the lower portion of a cylinder of diameter 50 mm and axis 70 mm when sectioned by a plane inclined at  $40^\circ$  to HP and perpendicular to VP and bisecting the axis. CO3-App (20)

Or

- (b) A hexagonal prism of base side 30 mm and axis length 60 mm is resting on HP on one of its bases with two of the vertical faces perpendicular to VP. It is cut by a plane inclined at  $50^\circ$  to HP and perpendicular to VP and passing through a point at a distance 12 mm to the top base. Draw its front view, sectional top view and true shape of section. CO3-App (20)

4. (a) A square pyramid of side 30 mm, axis length 50 mm is centrally placed on top of a cube of side 50 mm. Draw the isometric projection of the solids. CO4-App (20)

Or

- (b) Draw the perspective projection of a square prism of base side 40 mm and height 50 mm. One vertical face parallel to PP and 30 mm away from it. The station point is 80 mm from PP, 80 mm above the base and 60 mm to the right of the axis of the prism. CO4-App (20)

5. (a) Draw isometric view of the object from the views given below CO5-App (20)

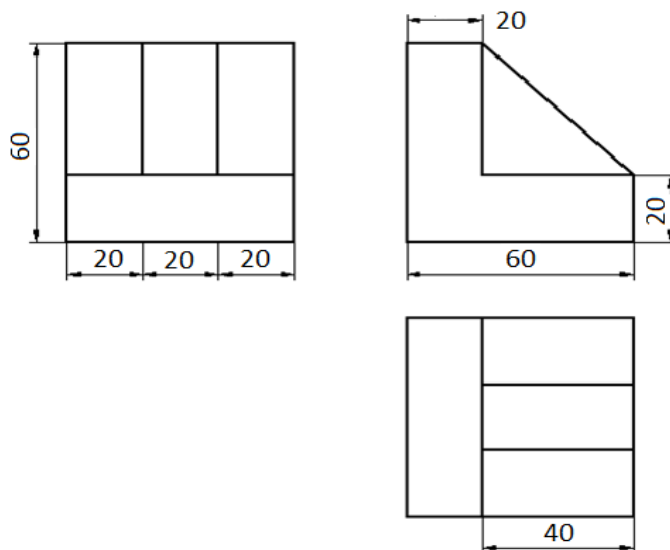

Or

(b) Draw orthographic views for the pictorial view given below.

CO5-App (20)

