

Reg. No. :

--	--	--	--	--	--	--	--	--	--

**Question Paper Code: 51007**

B.E./B.Tech. DEGREE EXAMINATION, MAY 2022

First Semester

Mechanical Engineering

01UME107 – ENGINEERING GRAPHICS

(Common to CSE and EEE branches)

(Regulation 2013)

Duration: Three hours

Maximum: 100 Marks

Answer ALL Questions.

(5 x 20 = 100 Marks)

1. (a) Sketch by free hand, the following views of the object shown in Figure 1. The dimensioning is also to be made by free hand.
- (1) the front view in the direction of the arrow (20)
  - (2) the top view
  - (3) the right side view

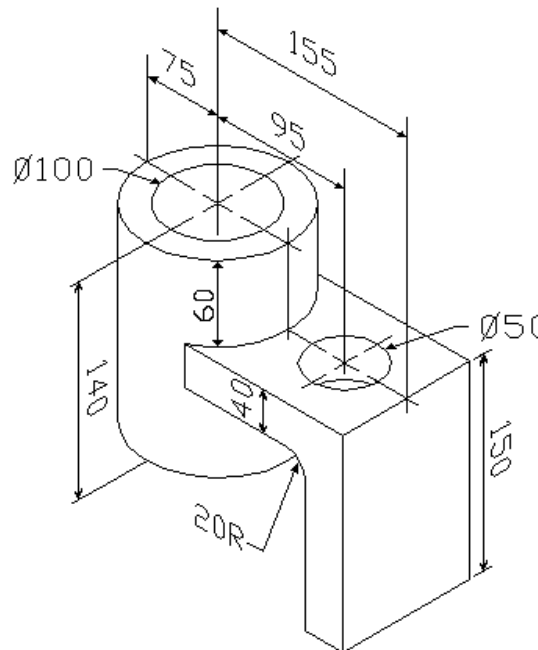

Or

(b) Sketch by free hand, the following views of the object shown in Figure 2.

(i) The front view in the direction of the arrow.

(ii) The top view and

(iii) The right side view.

The dimensioning is also to be done by free hand.

(20)

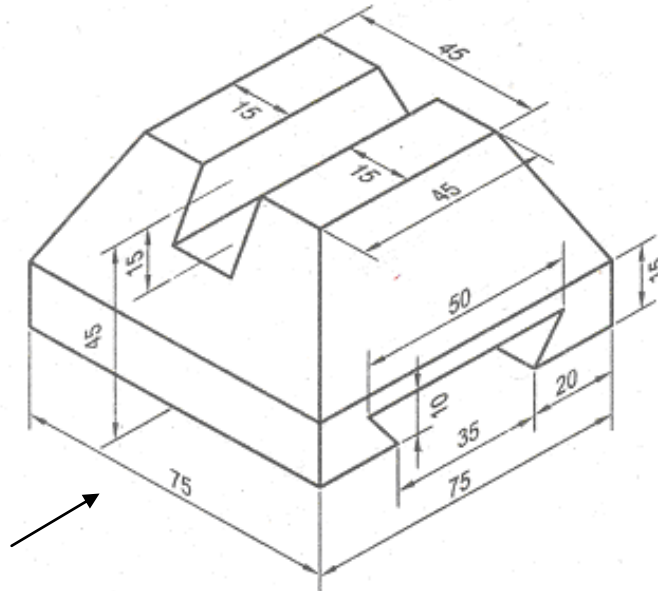

All dimensions are in 'mm'.

Figure 2

2. (a) A line AB measuring 85 mm has its end 'A' is 25 mm above the HP and 20 mm in front of the VP. The front view and top view measure 70 mm and 55 mm respectively. Draw the projections of the line and determine its true inclinations. (20)

Or

- (b) A regular hexagonal lamina of 35 mm sides has one edge in HP and inclined at an angle of  $30^\circ$  to VP. Draw its projection when its surface is inclined at  $45^\circ$  to HP. (20)

3. (a) A square pyramid base 32 mm side and axis 60 mm long is freely suspended from one of the corners of its base with the axis parallel to VP. Draw its projections. (20)

Or

(b) A hexagonal prism of base side 30 mm and axis 60 mm long is rest on HP on one of its base edge and its axis is inclined at  $50^\circ$  to the HP and parallel to VP. Draw its front and top views. (20)

4. (a) A pentagonal pyramid of base side 26 mm and altitude 52 mm is resting on H.P on its base with one of its base sides is perpendicular to V.P. It is cut by a plane inclined at  $45^\circ$  to H.P and perpendicular to V.P and is bisecting the axis. Draw the front view, sectional top view and true shape of the section. (20)

Or

(b) A cone of diameter 60 mm and height 70 mm is resting on its base on the ground. It is cut by a plane perpendicular to VP and parallel to HP at a distance 20 mm from the vertex. It is also cut by a plane inclined at  $40^\circ$  to the base and perpendicular to VP and meeting the axis at a point 20 mm from the base. Draw the development of the lateral surface of the remaining portion of the cone. (20)

5. (a) A flower vase is in the form of a frustum of a pentagonal pyramid, base 24 cm and top 40 cm side. Draw the isometric view of the flower vase, if the height is 54 cm. (20)

Or

(b) A hexagonal prism of base side 25 mm and height 50 mm rests on the HP and one of the edges of its base is parallel to VP. A section plane perpendicular to VP and inclined at  $50^\circ$  to HP bisects the axis of the prism. Draw the isometric projection of the truncated prism, showing the cut surface. (20)

---

