

A

Reg. No. :

--	--	--	--	--	--	--	--	--	--	--

Question Paper Code: 54303

B.E. / B.Tech. DEGREE EXAMINATION, APRIL 2024

Fourth Semester

Electrical and Electronics Engineering

15UEE403- CONTROL SYSTEMS

(Regulation 2015)

Duration: Three hours

Maximum: 100 Marks

Answer ALL Questions

PART A - (10 x 1 = 10 Marks)

1. Transfer function of a system is used to calculate which of the following? CO1-U
(a) The order of the system (b) The time constant
(c) The output for any given input (d) The steady state gain
2. The overall transfer function from block diagram reduction for cascaded blocks is given by CO1-U
(a) Sum of individual gain (b) Product of individual gain
(c) Difference of individual gain (d) Division of individual gain
3. If the characteristic equation of a closed-loop system is $s^2+2s+2=0$, then the system is CO2 -U
(a) Over damped (b) Critically damped (c) Under damped (d) undamped
4. Root locus is used to calculate CO2 -R
(a) Marginal stability (b) Absolute stability
(c) Conditional stability (d) Relative stability
5. The unit adopted for magnitude measurement in Bode plots is CO3-R
(a) Degree (b) Decimal (c) Decibel (d) Deviation
6. The frequency at which magnitude of closed loop response is ----- down from its zero frequency value is called as cut off frequency. CO3-R
(a) 0.3dB. (b) 30dB (c) 0.33dB (d) 3dB

7. For Nyquist contour, the size of radius is CO4-R
 (a) Zero (b) Unity (c) Infinity (d) Constant
8. The characteristic equation of a system is given as $3s^4 + 10s^3 + 5s^2 + 2 = 0$. CO4-U
 This system is :
 (a) Marginally stable (b) Stable (c) Unstable (d) Linear
9. State space analysis is applicable even if the initial conditions are CO5- U
 (a) Zero (b) Non-zero (c) Equal (d) Not equal
10. Solution of state equation is----- CO5 -R
 (a) $e^{-At}x(0)$ (b) e^{At} (c) $e^{At}x(0)$ (d) $-e^{At}x(0)$

PART – B (5 x 2= 10 Marks)

11. What is block diagram? What are the basic components of block diagram? CO1- U
12. List out the time domain specification. CO2- R
13. Define phase cross over frequency and gain cross over frequency. CO3- R
14. What are the necessary conditions for stability of a control system? CO4- R
15. Define State and State variables. CO5-U

PART – C (5 x 16= 80 Marks)

16. (a) Determine the transfer function $Y_2(S)/F(S)$ of the system shown in CO1- App (16)

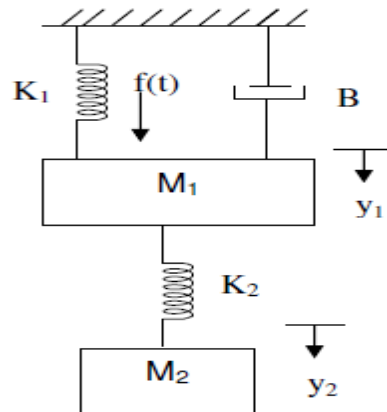

Or

- (b) Find the overall gain of the system whose signal flow graph is CO1- App (16)
 shown in figure.

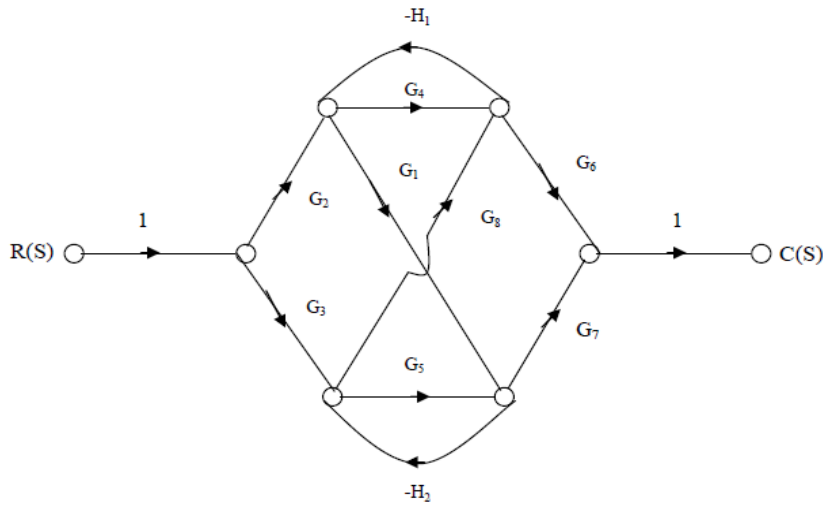

17. (a) Determine the generalized error coefficient and steady state error for a system whose open loop transfer function is $G(s) = 1/(S(S+1)(S+10))$ and the feedback transfer function is $H(s) = (S+2)$ with input $r(t) = 6 + t + t^2$ CO2- App (16)

Or

- (b) The open-loop transfer function of a control system is given as CO2 -App (16)

$$G(S)H(S) = \frac{K}{(S+1)(S+10)(S+30)}$$

.Draw the root locus. Obtain the value of K for which the system becomes unstable.

18. (a) The open loop transfer function of a unity feedback system is given by CO3- App (16)

$$G(S) = \frac{1}{S(S+1)(2S+1)}$$

. Sketch the polar plot and determine the gain margin and phase margin.

Or

- (b) Draw the circuit of a lag- lead compensator and drive its transfer function. What are the effects? CO3- App (16)

19. (a) Explain the procedure for the design of the lag compensator based on frequency response approach. CO4- Ana (16)

Or

- (b) Apply Nyquist stability criterion to the system with loop transfer function CO4- Ana (16)

$$G(s)H(s) = \frac{4s + 1}{s^2(1 + s)(1 + 2s)} \text{ And ascertain its stability.}$$

20. (a) The state model of the system is given by CO5- Ana (16)

$$\begin{bmatrix} \dot{x}_1 \\ \dot{x}_2 \\ \dot{x}_3 \end{bmatrix} = \begin{bmatrix} 0 & 1 & 0 \\ 0 & 0 & 1 \\ 0 & -2 & -3 \end{bmatrix} \begin{bmatrix} x_1 \\ x_2 \\ x_3 \end{bmatrix} + \begin{bmatrix} 0 \\ 0 \\ 10 \end{bmatrix} u;$$

$$y = [1 \quad 1 \quad 0] \begin{bmatrix} x_1 \\ x_2 \\ x_3 \end{bmatrix}$$

- (i) Find the transfer function for the given state model.
(ii) Determine whether the system is completely controllable and observable.

Or

- (b) Obtain a state space model of the system with transfer function CO5- Ana (16)

$$\frac{Y(s)}{U(s)} = \frac{6}{s^3 + 6s^2 + 11s + 6}$$