

Reg. No. :

|  |  |  |  |  |  |  |  |  |  |
|--|--|--|--|--|--|--|--|--|--|
|  |  |  |  |  |  |  |  |  |  |
|--|--|--|--|--|--|--|--|--|--|

**Question Paper Code: 12013**

M.E. DEGREE EXAMINATION, OCTOBER 2014.

First Semester

CAD / CAM

01PCD103 – INTEGRATED MECHANICAL DESIGN

(Regulation 2013)

Duration: Three hours

Maximum: 100 Marks

Answer ALL Questions.

PART A - (10 x 2 = 20 Marks)

1. What is meant by standardization?
2. How does BIS differ from ISO?
3. Distinguish between involute teeth and cycloidal teeth
4. Can you prefer cross helical gears for heavy load transmission? If not, why?
5. What do you understand by self energizing action in brakes?
6. Mention the types of brakes used in i) Tractor ii) Fork lift
7. What are the factors to be considered in escalator design?
8. Write any four practical applications of laminated springs.
9. What is crowning of pulley?
10. How is an automobile chain designated?

PART - B (5 x 14 = 70 Marks)

11. (a) (i) The fit between a hole and a shaft is  $\phi 70 H9f7$ . Find the allowance. (6)  
(ii) A bolt is subjected to an axial force of 10 kN with a transverse shear force of 5 kN, Find the diameter of the bolt required according to i.) Maximum distortion energy theory ii.) Maximum strain energy theory (8)

Or

- (b) (i) A shaft is to transmit 50 kW at 1250rpm. It is also subjected to a bending moment of 275 N-m. The shaft is not to twist more than  $2^\circ$  in a length of 2 m. Take modulus of rigidity is 80 kN/m<sup>2</sup>. Design the shaft. (10)
- (ii) Write notes on modular constructions. (4)

12. (a) A motor shaft rotating at 1440 rpm has to transmit 15 kW power to a low speed shaft rotating at 500 rpm. Pressure angle for gear and pinion (involute) teeth is  $20^\circ$ . The pinion has 25 teeth. Both gear and pinion are made of cast iron having allowable strength of 55 N/mm<sup>2</sup>. Design a suitable gear drive. (14)

Or

- (b) A pair of spiral bevel gears is used to transmit 2 kW at pinion speed of 1000 rpm and the gear speed to be 320 rpm. Design the gear drive by assuming suitable materials. (14)

13. (a) A differential band brake has a drum of diameter 800 mm. The two ends of the band are fixed to the pins on the opposite sides of the fulcrum of the lever at distance of 40 mm and 200 mm (from the fulcrum). The angle of contact is  $270^\circ$  and the coefficient of friction is 0.2. Determine the brake torque when a force of 600 N is applied to the lever at a distance of 800 mm from the fulcrum. (14)

Or

- (b) A double shoe brake as shown in figure, is capable of absorbing a torque of 1500 N-m. The Diameter of the brake drum is 400 mm and the angle of contact for each shoe is  $100^\circ$ . If the coefficient of friction between the brake drum and lining is 0.4, find the spring force necessary to set brake and the width of the brake shoe, if the pressure on the lining material is not to exceed  $0.3 \text{ N/mm}^2$ .

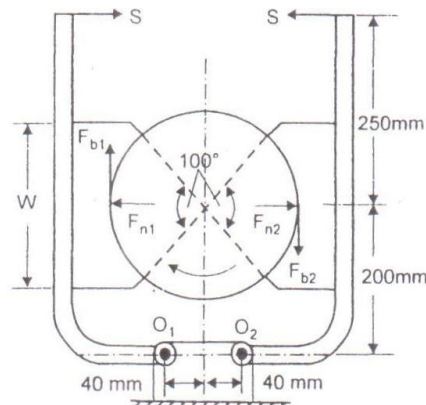

(14)

14. (a) Select a wire rope for a vertical mine hoist to lift a load of 20kN from a depth of 500m. A rope speed of 3 m/s is to be attained in 10 seconds. (14)

Or

- (b) A flywheel is to be designed to store 5 kN-m of energy and to keep the speeds between 395 and 405 rpm. The mean rim diameter is limited to 1 m. Design the flywheel, for which is used in an engine developing 20 kW. (14)

15. (a) what is a tangent cam? Derive the relations for velocity and acceleration for a convex cam with a flat –faced follower. (14)

Or

- (b) Design a drive with suitable V-belt for a wet grinder to the following conditions. Motor power is 0.5 kW at 750 rpm. Drum Speed is to be 100 rpm. (14)

PART - C (1 x 10 = 10 Marks)

16. (a) Two helical springs of the axial length, but different diameters of coils are placed coaxially one inside the other. The axial load is 3000 N and the deflection is 25 mm. The maximum permissible shear stress for both springs is 150Mpa. The spring indices are 5 and 9, the wire diameters being the same. Neglecting the effect of stress concentration, find the ratio of actual number of coils of two springs. (10)

Or

- (b) In a milling machine, 18 different speeds in the range from 35 rpm to 650 rpm are required. Design a three stage gear box with a standard step ratio. Sketch the layout of the gear box and indicates the number of teeth on each gear. The gear box receives 3.6 kW from an electric motor, running at 1440 rpm. Assume the suitable material for gears. (10)

---