

Reg. No. :

--	--	--	--	--	--	--	--	--	--

Question Paper Code: 11007

B.E./B.Tech. DEGREE EXAMINATION, DECEMBER 2013.

First Semester

Civil Engineering

01UME107 – ENGINEERING GRAPHICS

(Common to all branches)

(Regulation 2013)

Duration: Three hours

Maximum: 100 Marks

Answer ALL Questions.

(5 x 20 = 100 Marks)

1. (a) Sketch by free hand, the following views of the object shown in Figure 1. The dimensioning is also to be made by free hand. i) The front view in the direction of the arrow (F) ii) the top view and iii) the right side view. (20)

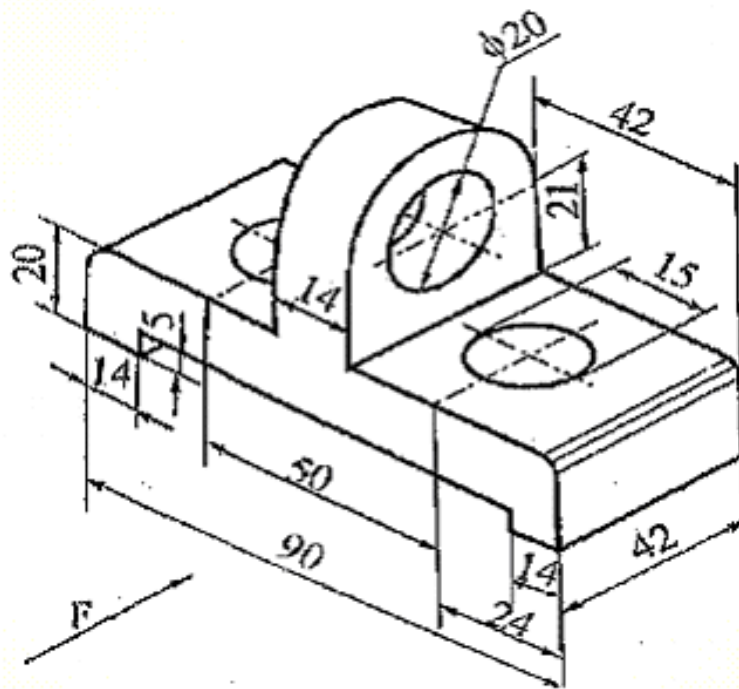
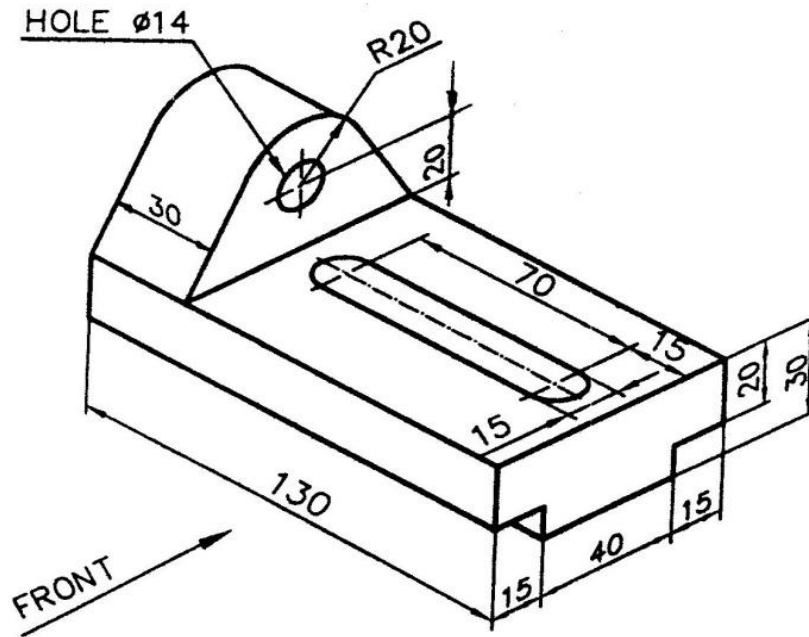

Figure 1

All dimensions are in mm

Or

- (b) Draw the plan, elevation and left side view of the following object. (20)



All dimensions are in 'mm'.

2. (a) A line AB measuring 85 mm has its end 'A' is 25 mm above the HP and 20 mm in front of the VP. The front view and top view measure 70 mm and 55 mm respectively. Draw the projections of the line and determine its true inclinations. (20)

Or

- (b) A regular pentagonal lamina of 30 mm sides has one edge in HP and inclined at an angle of 30° to VP. Draw its projection when its surface is inclined at 45° to HP. (20)
3. (a) A right circular cone of diameter 60 mm and height 70 mm is resting on the ground on one of the point on the circumference of its base with the axis parallel to the VP. Draw the projections of the cone if the end generator is perpendicular to HP. (20)

Or

- (b) Draw the projections of a cone of base diameter 50 mm and axis length 70 mm when it lies on the ground on its generators with the axis parallel to the VP. (20)

4. (a) A hexagonal pyramid of base side 25 mm and height 50 mm rests on the HP on one of its ends with two base edges parallel to the VP. It is cut by a plane perpendicular to the VP and inclined at 45° to the HP at a distance of 20 mm from the vertex on the axis. Draw the front view, sectional top view and true shape of the section. (20)

Or

- (b) A hexagonal pyramid of base side 25 mm and height 60 mm rests on the HP on its base with two of its base edges are perpendicular to the VP. It is cut by a plane perpendicular to the VP and inclined at 45° to the HP at a distance of 20 mm from the vertex on the axis. Draw the development of the lateral surfaces of the pyramid. (20)
5. (a) A concrete pillar is in the shape of hexagonal frustum with the side of base 0.5 m and the side of top face is 0.25 m. The height of the pillar is 2.5 m. Draw the isometric view of the pillar. Assume one of the base edges is parallel to the VP. (20)

Or

- (b) A dust bin is in the form of a hollow hexagonal pyramid with the base dimensions of 20 mm side and the top open surface of 45 mm sides. Draw the isometric view of the hollow dust bin, if its height is 50 mm and the wall thickness is negligible. (20)
-

