

Reg. No. :

--	--	--	--	--	--	--	--	--	--	--

Question Paper Code: 92012

M.E. DEGREE EXAMINATION, MAY 2014.

Elective

CAD / CAM

01PCD511 - ADVANCED MECHANICS OF MATERIALS

(Regulation 2013)

Duration: Three hours

Maximum: 100 Marks

Answer ALL Questions.

PART A - (10 x 2 = 20 Marks)

1. Write the stress-strain relation for plane stress condition.
2. State St. Venant's principle.
3. List the reasons to calculate shear centre of a cross-section of a beam.
4. Define Kern of a section.
5. Distinguish stress variation in straight beam and curved beam.
6. List the two important assumptions of thin plate theory.
7. The total shear stress on any cross section is zero. Explain the reason.
8. Write the Prandtl's stress function.
9. Give two examples of practical problems which can be approximated as rotating disks of uniform thickness.
10. State the important assumptions made during the calculation of Hertz's contact stresses.

PART - B (5 x 14 = 70 Marks)

11. (a) Show that the Airy's stress function $\phi = \frac{A}{b^2} (y^2 - \frac{1}{2} h^2) x^2$ represents stress distribution in a cantilever beam loaded at the free end with load P. Find the value of A if $\tau_{xy} = 0$ at $y = \pm \frac{h}{2}$ - where b and h are width and depth respectively of the cantilever. (14)

Or

- (b) Derive the equations of equilibrium in cylindrical co-ordinates. (14)
12. (a) Determine the shear stress distribution in a channel section of a cantilever beam subjected to a load F, as shown in Figure 1. Also, locate the shear centre of the section.

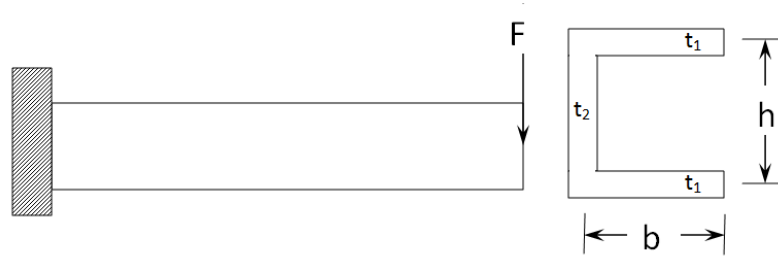

Figure 1. (14)

Or

- (b) A beam of equal-leg angle section, shown in Figure 2, is subjected to its own weight. Determine the stress at point A near the built-in section. It is given that the beam weighs 1.48 N/cm. The principal moments of inertia are 284 cm^4 and 74.1 cm^4 .

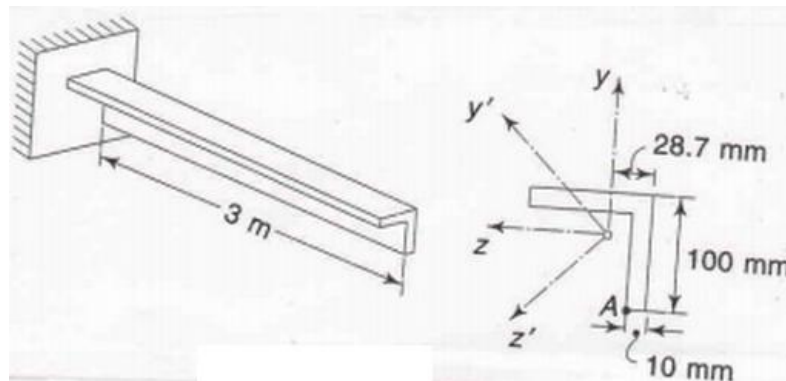

Figure 2. (14)

13. (a) Derive the relation between stress and bending moment of a curved beam based on Winkler's theory. (14)

Or

- (b) A simply supported rectangular plate of sides 400 mm and 600 mm carries a uniformly distributed load of intensity 10 N/mm^2 . Determine the maximum deflection and the maximum stresses in the plate. Assume Poisson's ratio as 0.3 and $E = 2 \times 10^5 \text{ N/mm}^2$ and thickness of the plate 15 mm. (14)
14. (a) A torque T is applied to (a) solid square, (b) a rectangular bar with ratio of sides as 1:2. The areas of cross-section are equal. Find their angles of twist and maximum stresses and compare these with solid circular bar of the same area. (14)

Or

- (b) Thin tubular bar shown in Figure 3 is under the action of a torque of 10 kNm. Find the shearing stresses in the tube.

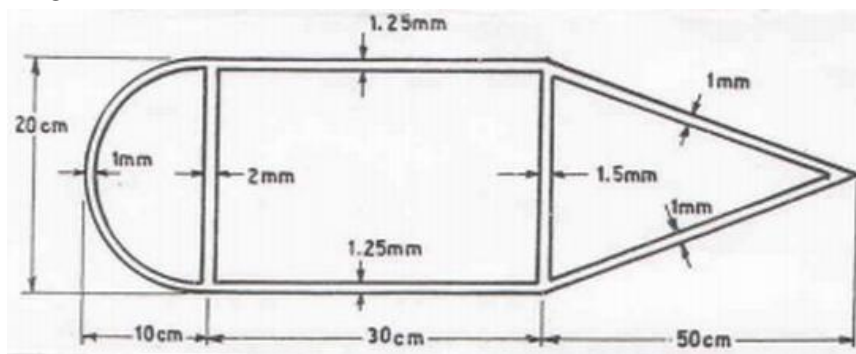

Figure 3. (14)

15. (a) A flat steel disk of 75 cm outside diameter with a 15 cm diameter hole is shrunk around a solid steel shaft. The shrink-fit allowance is 1 part in 1000 (i.e., an allowance of 0.0075 cm in radius). $E = 214 \times 10^6 \text{ kPa}$.
- What are the stresses due to shrink-fit.
 - At what rpm will the shrink-fit loosen up as a result of rotation?
 - What is the circumferential stress in the disk when spinning at the above speed? (14)

Or

- (b) The radii of curvature of the two surfaces of semi circular discs at the point of contact are $R'_1 = 60$ mm, $R''_1 = 130$ mm, $R'_2 = 80$ mm, $R''_2 = 200$ mm. Then angle α between the planes of minimum curvature is 60° . If a load of $P = 4.5$ KN is applied, determine the maximum principal stress, maximum shearing stress, and locate the point where each of these stresses occur. Take $E_1 = E_2 = 200$ GPa and $\nu_1 = \nu_2 = 0.29$. (14)

PART - C (1 x 10 = 10 Marks)

16. (a) A steel gun barrel is subjected to an internal pressure of 70 MPa. The internal diameter of the barrel is 75 mm and external diameter of 225 mm. A steel band 25 mm thick and internal diameter 0.75 mm smaller than the external diameter of the gun barrel is shrunk on the gun barrel. Calculate (i) the shrinkage pressure on the gun barrel, (ii) maximum stress in the steel band and (iii) minimum temperature to which the band must be heated to make the assembly. For steel $E = 200$ GPa, $\nu = 0.3$ and coefficient of thermal expansion = $10 \times 10^{-6}/^\circ\text{C}$. (10)

Or

- (b) A steel railway car wheel may be considered to be approximately a cylinder with a radius of 440 mm. The wheel rolls on a steel rail whose top surface may be considered to be approximately another cylinder with a radius of 300 mm. For the wheel and rail, $E = 200$ GPa and $\nu = 0.29$. If the wheel load is 110 kN, determine the maximum principal stress and maximum shear stress. Also determine the vertical displacement of the centre of the wheel due to deflections in the region of contact. (10)