

Reg. No. :

--	--	--	--	--	--	--	--	--	--

Question Paper Code: 50126

B.E. / B.Tech. DEGREE EXAMINATION, MAY 2017

Second Semester

Civil Engineering

15UCE206 - BASIC ENGINEERING MECHANICS

(Regulation 2015)

Duration: Three hours

Maximum: 100 Marks

Answer ALL Questions

PART A - (10 x 1 = 10 Marks)

1. If two forces of 3kg and 4kg act at right angles to each other, their resultant force will be equal to
(a) 7kg (b) 1kg (c) 5kg (d) 1/7kg
2. Effects of a force on a body depends upon its
(a) Direction (b) Magnitude (c) Position (d) All the above
3. The velocity ratio of an inclined plane of inclination θ with horizontal for lifting a load is
(a) $\sin \theta$ (b) $\cos \theta$ (c) $\tan \theta$ (d) $\operatorname{cosec} \theta$
4. All joints in truss are assumed to be
(a) Pin support (b) Fixed support (c) Hinged support (d) Roller support
5. The coefficient of friction depends on
(a) Area of Contact (b) Shape of surface
(c) Strength of surfaces (d) Nature of surfaces
6. The ratio of limiting friction and normal reaction is known as
(a) Coefficient of friction (b) Angle of friction
(c) Sliding friction (d) Friction resistance

7. The center of gravity of a semi-circle lies at a distance of _____ from its base measured along the vertical radius.
- (a) $4r / 3\pi$ (b) $3r / 8$ (c) $3r / 4\pi$ (d) $4r / 6\pi$
8. The point, through which the whole weight of the body acts, irrespective of its position, is known as
- (a) centre of percussion (b) moment of inertia
(c) centre of mass (d) centre of gravity
9. Moment of inertia is the
- (a) Second moment of area (b) Second moment of force
(c) Second moment of mass (d) All of these
10. The units of the moment of inertia of an area are
- (a) Kg m^2 (b) Kg / m^2 (c) Kg m^4 (d) Kg / m^4

PART - B (5 x 2 = 10 Marks)

11. Define resultant force.
12. What are the different types of supports.
13. Classify the types of friction.
14. Define centroid.
15. State parallel axis theorem.

PART - C (5 x 16 = 80 Marks)

16. (a) Two rollers each of weight 50N and of radius 10cm rest in a horizontal channel of width 36cm as shown in fig. 1. Find the reaction on the point of contacts A, B and C. (16)

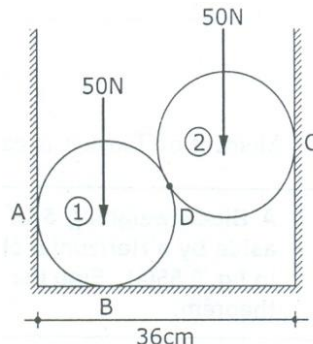

Figure 1

Or

- (b) A string ABCD, attached to two fixed points A and D has two equal weights of 1000N attached to it at B and C. The weights rest with the portions AB and CD inclined at angles of 30° and 60° respectively, to the vertical as shown in fig. 2. Find the tensions in the portions AB, BC and CD of the string, if the inclination of the portion BC with the vertical is 120° . (16)

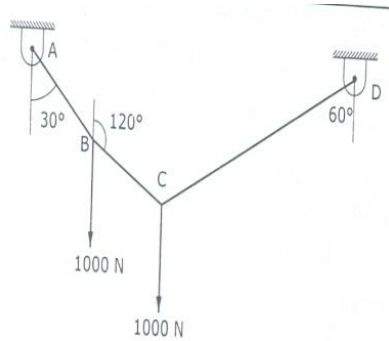

Figure 2

17. (a) Determine the support reaction of the beam as shown in fig. 3. (16)

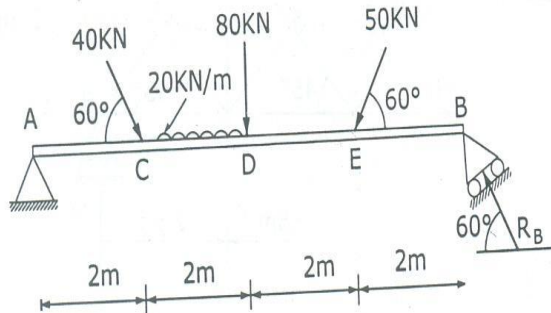

Figure 3

Or

- (b) Find the support reactions of a truss, loaded as shown in fig.4. (16)

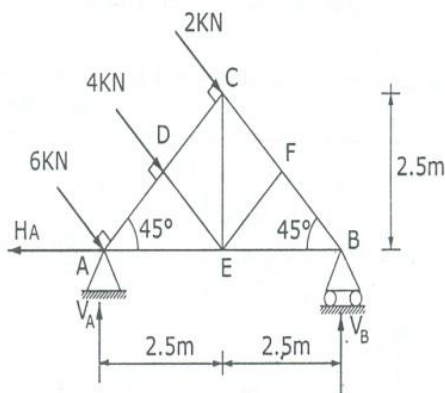

Figure 4

18. (a) A uniform ladder of weight 1000N and length 4m rests on a horizontal ground and leans against a smooth vertical wall. The ladder makes an angle of 60° with horizontal. When a man of weight 750N stands on the ladder, the ladder is at the point of sliding. Determine the coefficient of friction between the ladder and the floor. (16)

Or

- (b) A 100kg mass is lifted by a rope, rolling on a cylinder of 150mm diameter as shown in fig.5. Determine the force required on the other side if the coefficient of friction is 0.20. Also calculate the torque and power transmitted, if the velocity is 30m/sec. (16)

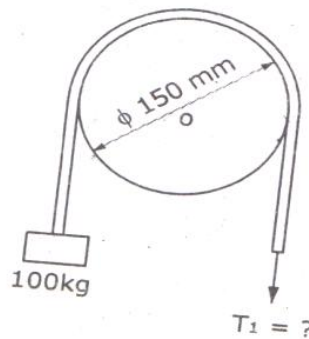

Figure 5

19. (a) Locate the centroid of the sectioned area shown in fig.6. (16)

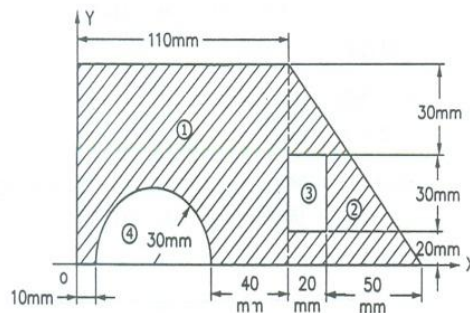

Figure 6

Or

- (b) Locate the centroid of the given section as shown in fig.7. (16)

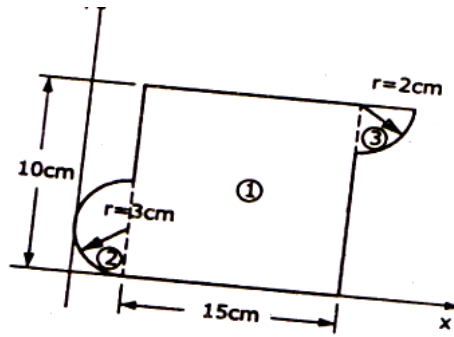

Figure 7

20. (a) Find the moment of inertia of the section about its centroidal axis as shown in fig.8. (16)

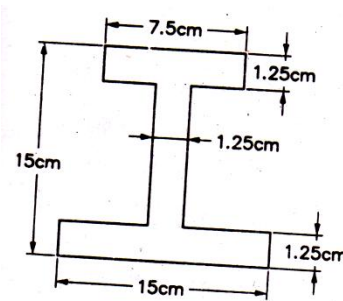

Figure 8

Or

- (b) Locate the principal axes and determine the principal moments of inertia of an angle section as shown in fig.9. (16)

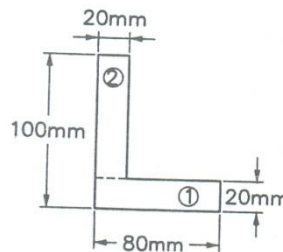

Figure 9

