

Reg. No. :

--	--	--	--	--	--	--	--	--	--

Question Paper Code: 33403

B.E. / B.Tech. DEGREE EXAMINATION, MAY 2018

Third Semester

Electronics and Communication Engineering

01UEC303 - CIRCUIT THEORY

(Regulation 2013)

Duration: Three hours

Maximum: 100 Marks

Answer ALL Questions

PART A - (10 x 2 = 20 Marks)

1. Define Tree and Co-tree
2. Give the properties of tree in a graph.
3. State maximum power transfer theorem
4. State Norton's theorem.
5. When the current is maximum in the series resonance circuit? Why?
6. Write the properties of a parallel RLC circuit.
7. Give the conditions for balanced star connected load.
8. Give the line and phase values in delta connection?
9. What is impedance matching?
10. List down the difference between single port network and dual port network.

PART - B (5 x 16 = 80 Marks)

11. (a) Derive expressions for star connected arms in terms of delta connected arms and delta Connected arms in terms of star connected arms. (16)

Or

- (b) (a) (i) Find the node voltage V_a and V_b which is shown in Figure -3 (16)

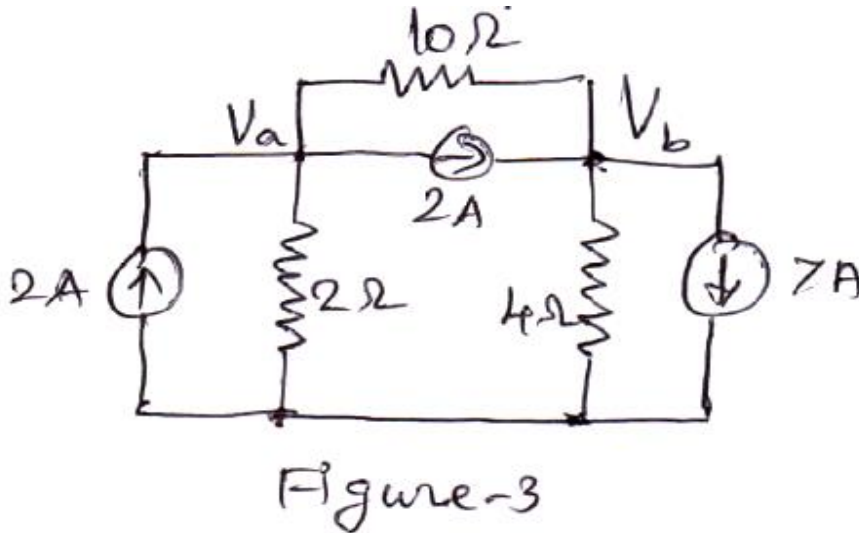

12. (a) State and explain Maximum power transfer theorem. Also give its applications. (16)

Or

- (b) Determine the Thevenin's equivalent circuit across AB in fig. (16)

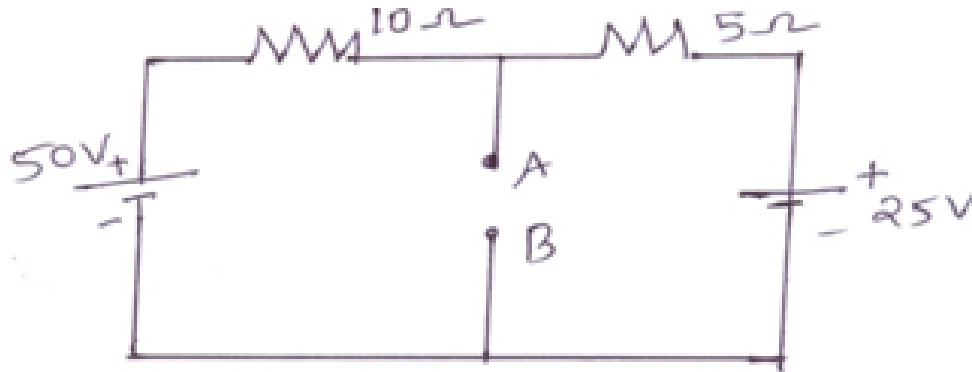

13. (a) A voltage $v(t) = 10 \sin \omega t$ is applied to a series RLC circuit. At the resonant frequency of the circuit, the maximum voltage across the capacitor is found to be 500V. Moreover the bandwidth is known to be 400 rad/sec and the impedance at resonance is 100Ω . Find the resonant frequency. Also find the values of L and C of the circuit. (16)

Or

- (b) Discuss the response of circuits for non sinusoidal period inputs with an example. (16)

14. (a) With a neat circuit and phasor diagram explain the three phase power measurement by two wattmeter methods. (16)

Or

- (b) Explain in detail about single and double tuned circuits. (16)

15. (a) The impedance parameters of a 2 port network are

$$Z_{11} = 6\Omega, Z_{22} = 4\Omega, Z_{12} = Z_{21} = 3\Omega$$

Compute Y parameters and $ABCD$ parameters. (16)

Or

- (b) Find transmission parameters for the low pass filter network shown in figure. (16)

