

27/12/16 FN

Reg. No. :

--	--	--	--	--	--	--	--	--	--	--	--	--	--	--	--	--	--	--	--

**Question Paper Code : 60863**

B.E./B.Tech. DEGREE EXAMINATION, NOVEMBER/DECEMBER 2016.

Seventh Semester

Mechanical Engineering

ME 2401/ME 71/ME 1402/10122 ME 702 — MECHATRONICS

(Common to Production Engineering)

(Regulations 2008/2010)

(Common to PTME 2401/10122 ME 702 – Mechatronics for B.E. (Part-Time)  
Fifth Semester – Mechanical Engineering – Regulations 2009/2010)

Time : Three hours

Maximum : 100 marks

Answer ALL questions.

PART A — (10 × 2 = 20 marks)

1. What is a control system?
2. Full scale reading of voltmeter is 100 V. The accuracy of voltmeter is specified as  $\pm 1\%$  of true value. What is probable range of reading shown by voltmeter while measuring voltage of 50 V?
3. Why the air is to be treated before its application in industry?
4. Why servo motor is preferred in automatic control system.
5. What are the limitations of permanent-magnet stepper motor?
6. Why is logical control so popular when continuous control allows more precision?
7. What is the importance of scan cycle in operation of a PLC?
8. State the logical relationship between a normally open contact and a normally closed contact with the same address.
9. Mention the constraints in Mechatronics system design.
10. What is an engine management?

PART B — (5 × 16 = 80 marks)

11. (a) Explain the various elements of a closed loop control system with an example of speed control of a shaft. (16)

Or

- (b) (i) What is the basic principle used in Level Measurement System? Explain with neat diagram. (8)
- (ii) What is RTD? Explain the relationship between resistance and temperature for the RTD with temperature resistance curve. (8)
12. (a) (i) A hydraulic cylinder is to be used to move a work piece in a manufacturing operation through a distance of 50 mm in 10 sec. A force of 10 kN is required to move the work piece. Determine the required working pressure and hydraulic liquid flow if a cylinder with a piston diameter of 100 mm is available. (8)
- (ii) What are the various types of ball bearing? Mention the application of each type. (8)

Or

- (b) (i) Briefly describe the functioning of servomotors with a neat diagram. (8)
- (ii) Explain thyristors and triacs in detail. (8)
13. (a) (i) Explain the governing equations of the following mechanical systems used in vehicle suspension. (10)

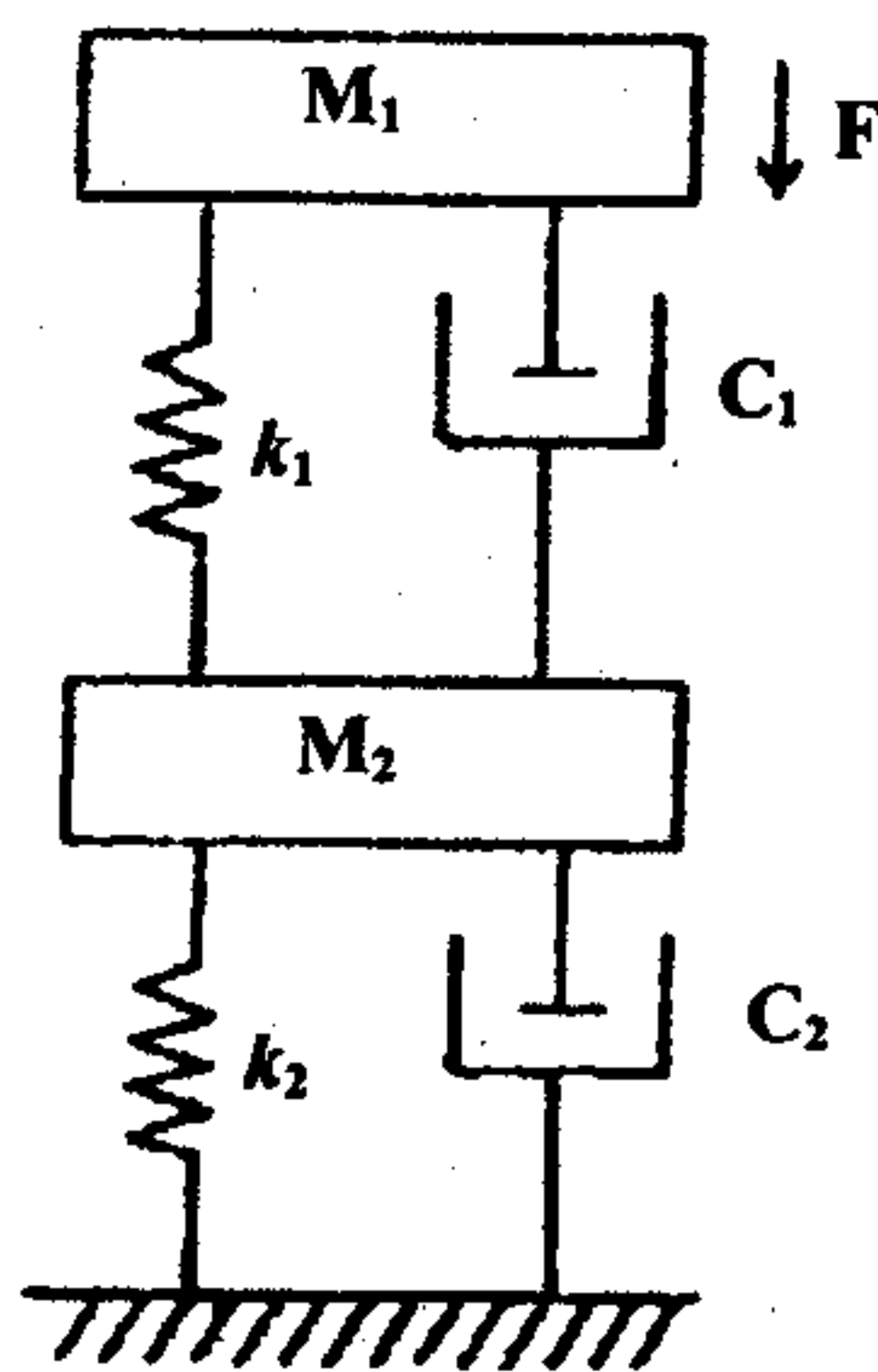

- (ii) Write short notes on : Force to voltage analogy and force to current analogy. (6)

Or

- (b) (i) Write a note on modeling of thermal systems. (8)
- (ii) Explain dynamic response of first order system to a step input. (8)

14. (a) (i) Device a system using a PLC which can be used to get continuous reciprocating motion of the actuator and end positions of the stroke are maintained for 10 seconds. (8)
- (ii) Describe the Master Control Relay (MCR) function. (8)

Or

- (b) (i) Explain use of shift registers with the help of suitable example. (6)
- (ii) Write a ladder diagram program for the given case: A conveyor is run by switching on or off a motor. The parts on the conveyor are positioned by an optical detector. When the optical sensor goes on, to wait 1.5 seconds, and then stop the conveyor. After a delay of 2 seconds the conveyor will start again. Use a start and stop button - a light should be on when the system is active. (10)
15. (a) What are the various stages in designing a Mechatronics system? Explain.

Or

- (b) Explain the working of an automatic car parking system with neat sketch. (16)