

6/6/16 FN

Reg. No.

--	--	--	--	--	--	--	--	--	--	--	--	--	--	--	--	--	--	--	--

Question Paper Code : 51843

B.E./B.Tech. DEGREE EXAMINATION, MAY/JUNE 2016

Second Semester

Civil Engineering

ME 2151/ME 25/080120002/CE 1151/10122 ME 205 – ENGINEERING MECHANICS

**(Common to Aeronautical, Automobile, Marine, Mechanical, Production, Chemical, Petroleum Engineering, Biotechnology, Polymer, Textile, Textile (Fashion), Plastic Technology, Materials Science and Engineering, Manufacturing Engineering, Mechatronics Engineering, Industrial Engineering, Industrial Engineering and Management, Environmental Engineering, Geoinformatics, Mechanical and Automation Engineering, Petrochemical Engineering, Chemical and Electrochemical Engineering, Petrochemical Technology, Pharmaceutical Technology, Textile Chemistry and Mechanical Engineering (Sandwich))
(Regulations 2008/2010)**

(Common to 10122 ME 205 – Engineering Mechanics for BE. (Part-Time) First Semester – Mechanical Engineering – Regulations 2010)

Time : Three Hours

Maximum : 100 Marks

Answer ALL questions.

PART – A (10 × 2 = 20 Marks)

1. State "Lames Theorem".
2. Differentiate between "Force" and "Moment".
3. What are the different types of "Loads" and "Support" ?
4. State the conditions of equilibrium of a rigid body in two dimensions.
5. What do you understand by first moment of area ?
6. State the theorem of Parallel axis.

7. Write the expression for relative velocity in plane motion.
8. Define the term co-efficient of restitution.
9. What is called a circle of friction ?
10. Cite two examples for motion of several particles.

PART - B (5 × 16 = 80 Marks)

11. (a) Four forces of magnitudes 15 kN, 30 kN, 40 kN and 60 kN are acting at a point O as shown in figure 1. Determine the magnitude, direction and position of the resultant force. (16)

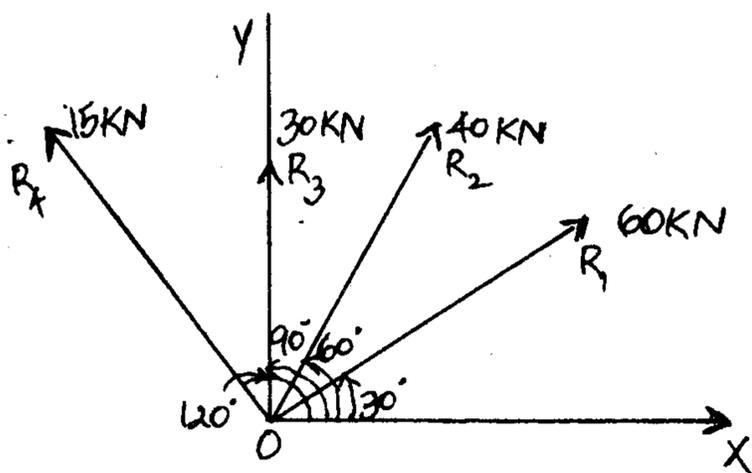

Fig. 1

OR

- (b) Determine the tension in cables AB and AC necessary to support the 80 kg debris shown in figure. 2. (16)

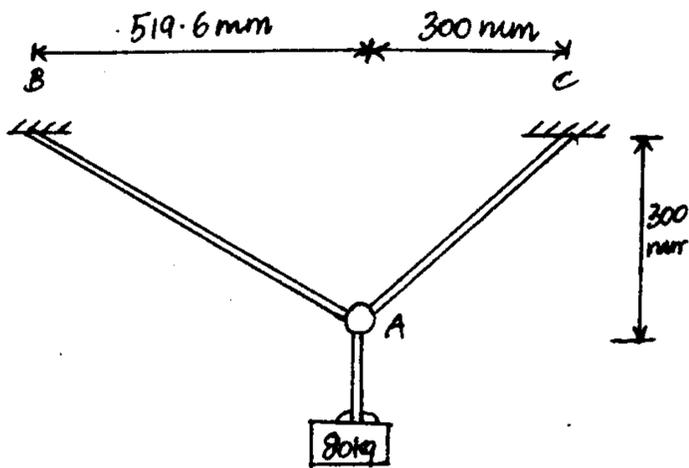

Fig. 2

12. (a) Determine the reactions at the hinged support A and the roller support B as shown in figure 3. (16)

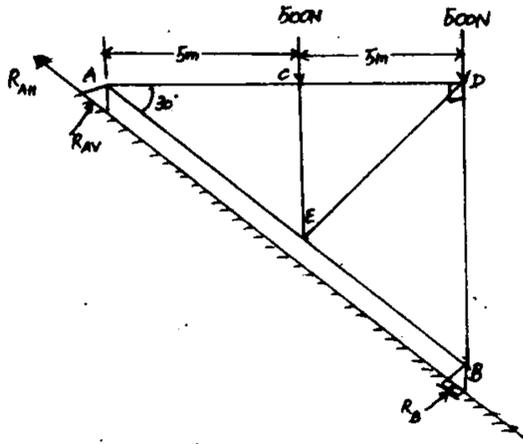

Fig. 3

OR

- (b) A cement electric post weighing 215 kg and of length 6 m is raised by erecting it in a position by pulling a wire rope attached to it as shown in figure 4. Determine the tension in the rope and reaction at A. (16)

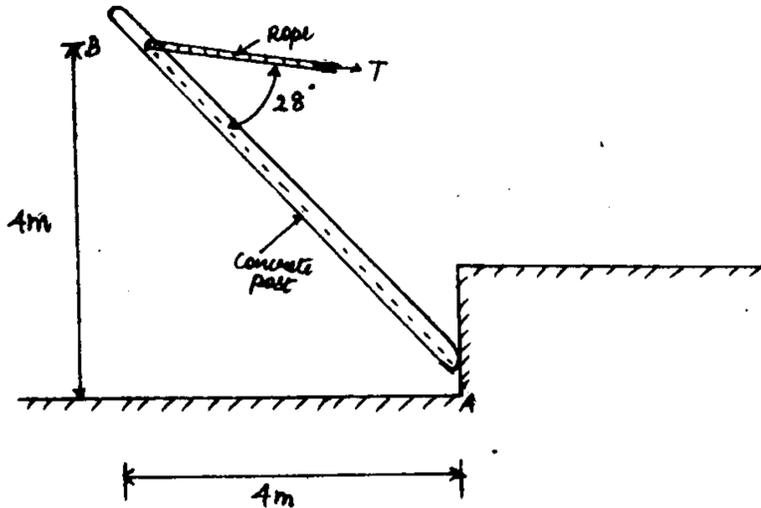

Fig. 4

- 13 (a) Figure 5 shows a I section of dimensions in mm. Determine the moment of Inertia of the section about the horizontal and vertical axes, passing through the centre of gravity of the section. (16)

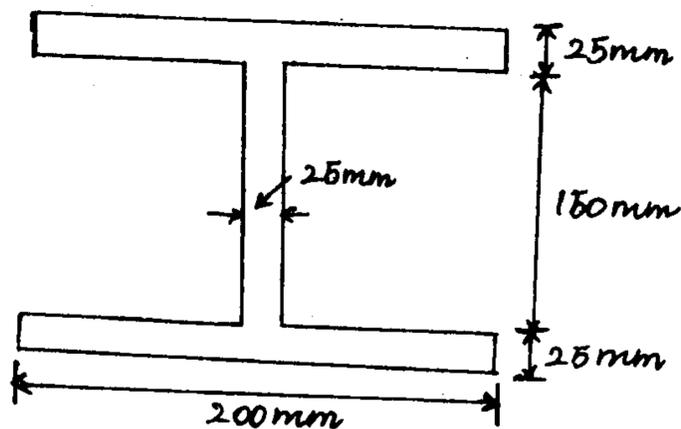

Fig. 5

OR

- (b) Determine the mass moment of Inertia of the cylindrical prism shown in figure 6 with respect to y-axis by direct integration. [16]

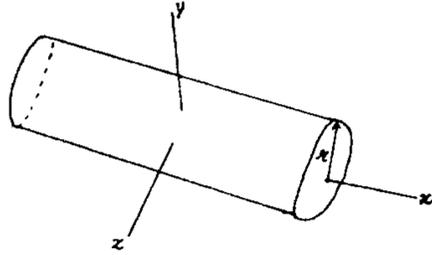

Fig. 6

14. (a) Car A is accelerating in the direction of its motion at the rate of 1.7m/s^2 and at the instant shown in figure 7. It has a speed of 25m/s . Car B is moving along a circular path at 20m/s and decreasing its speed at the rate of 2.8m/s^2 . Determine the velocity and acceleration of B as measured by the driver A [16]

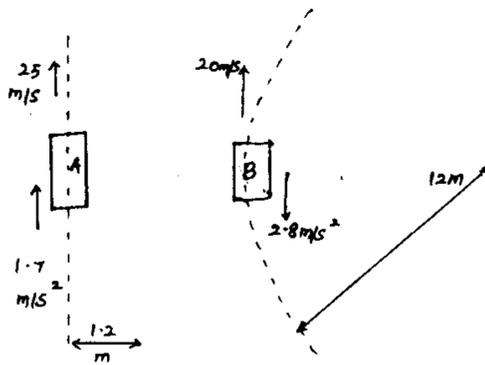

Fig. 7
OR

- (b) A bullet of mass 10gm is fired into a body of mass 1.5kg , which is suspended by a string of 1m long. The bullet gets embedded in the body and due to the impact, the body swings through an angle of 19.3° as shown in figure 8. Determine the velocity of the bullet. [16]

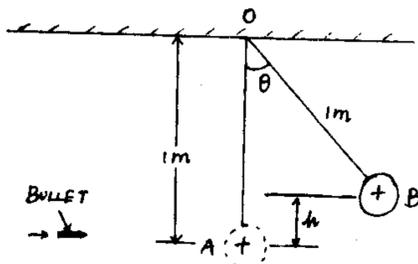

Fig. 8

- 15 (a) A uniform ladder of length 12m and weighing 30N is placed against a smooth vertical wall with its lower end 8m from the wall. In this position the ladder is just to slip.
Find : (i) the co-efficient of friction between the ladder and the floor and
(ii) frictional force acting on the ladder at the point of contact between ladder and floor. [16]

OR

- (b) A flywheel has an angular speed of 2200rev/min . when its motor is turned off. The wheel attains a constant deceleration of 2.5rad/s^2 due to friction in its bearing. Determine the time required for the wheel to come to rest and the number of revolutions the wheel makes before it comes to rest. [16]