

Reg. No. :

--	--	--	--	--	--	--	--	--	--	--

Question Paper Code: 34051

B.E. / B.Tech. DEGREE EXAMINATION, NOV 2017

Fourth Semester

Electronics and Instrumentation Engineering

01UEI401 – CONTROL ENGINEERING

(Regulation 2013)

Duration: Three hours

Maximum: 100 Marks

Answer ALL Questions

PART A - (10 x 2 = 20 Marks)

1. Define Transfer function of a system.
2. State the rule for shifting the summing point ahead of a block.
3. Define steady state error.
4. What is positional error coefficient? Explain.
5. What are the frequency domain specifications.
6. What is compensator?
7. What is the necessary and sufficient condition for stability?
8. Define centroid.
9. Define sampling theorem.
10. Write the solution of homogeneous state equations.

PART - B (5 x 16 = 80 Marks)

11. (a) Find the transfer function $V_0(S) / V_i(S)$ of the given electrical network.

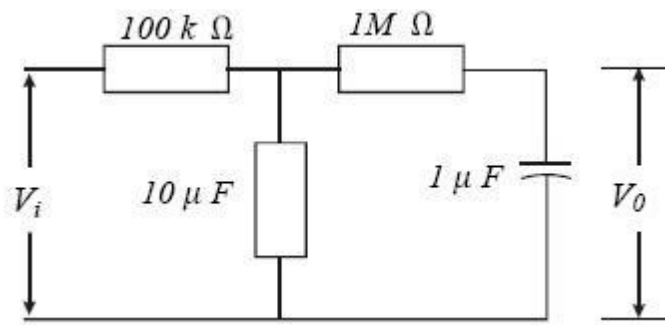

(16)

Or

- (b) Draw the signal flow graph and find $C(S) / R(S)$ using Mason's gain formula for the system shown in figure. (16)

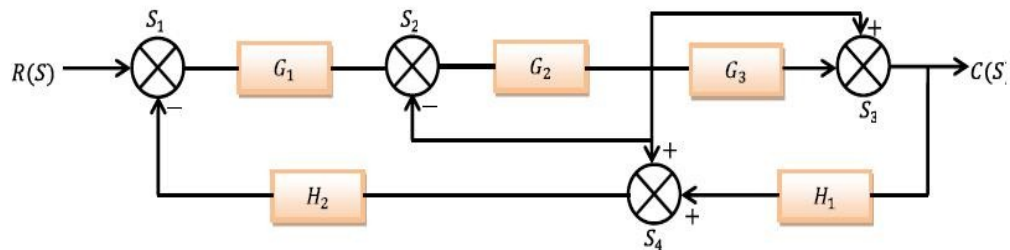

12. (a) The open loop transfer of a feedback control system with unity feedback given by

$$G(s) = \frac{40}{s(1 + 0.5s)}$$

Find the error constants for the system. Also obtain the steady state error when the input is $r(t) = 1 + 5t + 10t^2$. (16)

Or

- (b) Closed loop transfer function of a system with unity feedback is given by $C(s)/R(s) = (Ks + b) / (s^2 + as + b)$. Find the open loop transfer function $G(s)$ and also show that Steady state error with unit ramp input is given by $(a-k) / b$. (16)

13. (a) The open loop transfer function of unity feedback system is given by

$$G(s) = \frac{10(s + 2)}{s(s + 1)(s + 3)}$$

Sketch the polar plot and determine the gain margin and phase margin. (16)

Or

(b) A unit step input is applied to a unity feedback control system having open loop transfer function $G(s) = \frac{K}{s(1+sT)}$. Determine the values of K and T to have $M_p = 20\%$ and resonant frequency $\omega_r = 6 \text{ rad/sec}$. Calculate the resonant peak M_r . (16)

14. (a) Sketch the root locus for the unity feedback system whose open loop transfer function is given by $G(s) = \frac{K}{s(s^2 + 6s + 10)}$. Determine the range of 'K' for which the system to be stable. (16)

Or

(b) Using Nyquist Criterion obtain the range of values of K for which the system with open loop transfer function $G(s)H(s) = \frac{K(s+1)}{[s^2(s+2)(s+4)]}$ (16)

15. (a) A LTI system is characterized by the state equation

$$\begin{bmatrix} \dot{x}_1 \\ \dot{x}_2 \end{bmatrix} = \begin{bmatrix} 1 & 0 \\ 1 & 1 \end{bmatrix} \begin{bmatrix} x_1 \\ x_2 \end{bmatrix} + \begin{bmatrix} 0 \\ 1 \end{bmatrix} u$$

Where 'u' is a unit step function. Compute the solution of these equation assuming

initial condition $x_0 = \begin{bmatrix} 1 \\ 0 \end{bmatrix}$ (16)

Or

(b) Derive the relationship between the state equation and transfer function. (16)

