

L1B
2/12/13FW

Reg. No.

--	--	--	--	--	--	--	--	--	--	--	--	--	--	--	--	--	--	--	--

Question Paper Code : 31560

B.E./B.Tech. DEGREE EXAMINATION, NOVEMBER/DECEMBER 2013.

Third Semester

Mechanical Engineering

ME 2204/CE 3213/ME 34/CE 1208/10122 ME 305/080180007/IE 41 – FLUID
MECHANICS AND MACHINERY

(Common to Aeronautical Engineering, Automobile Engineering, Production
Engineering, Mechatronics Engineering, Mechanical and Automation Engineering
and Fourth Semester Manufacturing Engineering, Industrial Engineering and
Industrial Engineering and Management)

(Regulation 2008/2010)

(Common to PTCE 3213 – Fluid Mechanics and Machinery for B.E. (Part-Time)
Third Semester – Manufacturing Engineering Regulation 2009)

Time : Three hours

Maximum : 100 marks

Any missing data can be suitably assumed with justification.

Answer ALL questions.

PART A — (10 × 2 = 20 marks)

1. What is cavitation? What causes it?
2. Differentiate between kinematic viscosity of liquids and gases with respect to pressure.
3. How does surface roughness affect the pressure drop in a pipe if the flow is turbulent?
4. A piping system involves two pipes of different diameters (but of identical length, material, and roughness) connected in parallel. How would you compare the flow rates and pressure drops in these two pipes?
5. The excess pressure Δp inside a bubble is known to be a function of the surface tension and the radius. By dimensional reasoning determine how the excess pressure will vary if we double the surface tension and the radius.
6. Determine the dynamic pressure exerted by a flowing incompressible fluid on an immersed object, assuming the pressure is a function of the density and the velocity.

7. What is meant by hydraulic efficiency of turbine?
8. Define – manometric head and write its mathematical equation.
9. Draw the relationship between discharge and crank angle for a single acting pump.
10. Mention the significance of 'back leakage'.

PART B — (5 × 16 = 80 marks)

11. (a) (i) Water enters the bottom of the cone in Fig. 1. at a uniformly increasing average velocity $V = Lt$. If d is very small, derive an analytic formula for the water surface rise $h(t)$, assuming $h = 0$ at $t = 0$. (8)

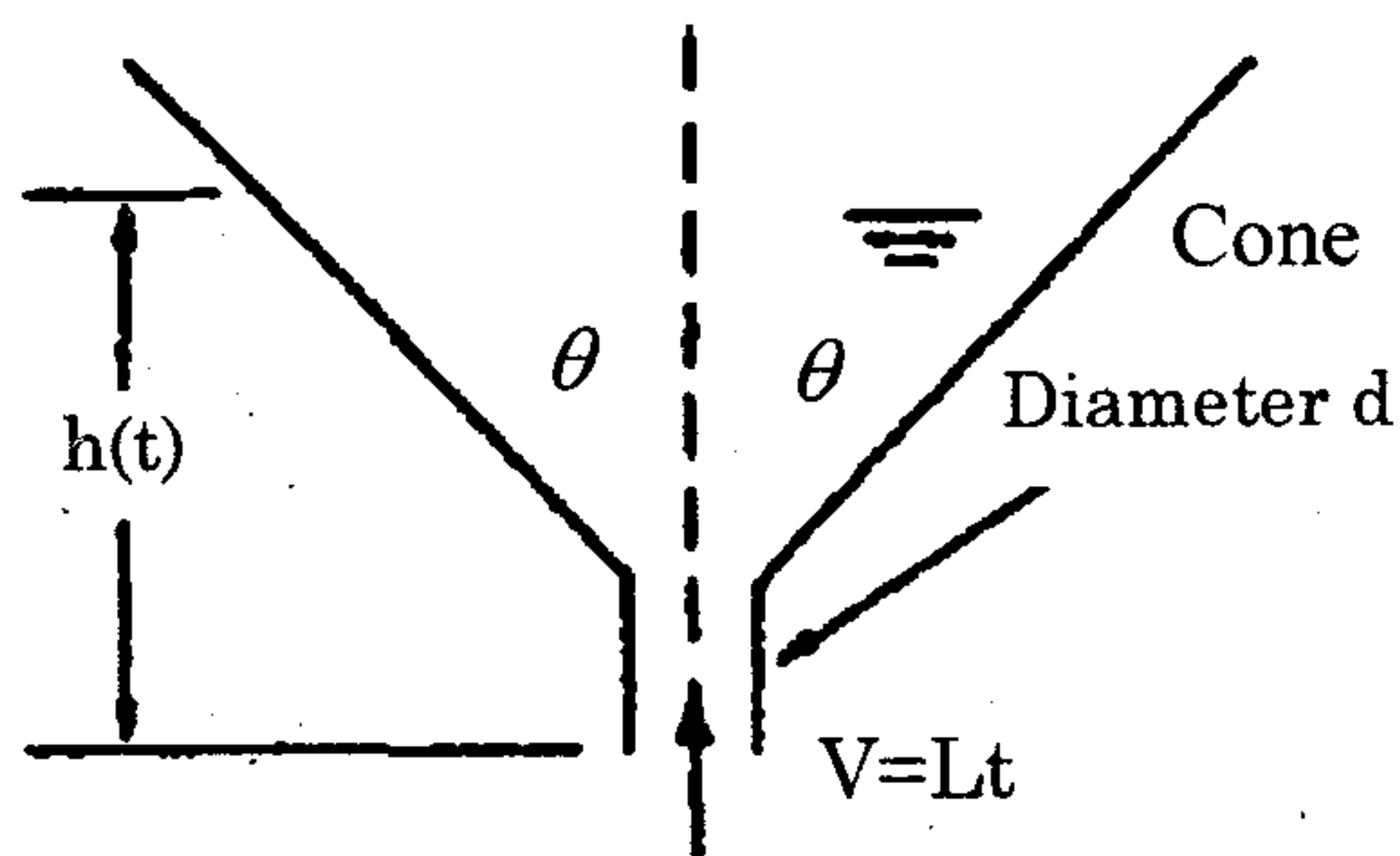

Fig. 1

- (ii) According to Torricelli's theorem, the velocity of a fluid draining from a hole in a tank is $V \cong (2gh)^{1/2}$, where h is the depth of water above the hole. Let the hole have area A_o and the cylindrical tank have bottom area A_b . Derive a formula for the time to drain the tank from an initial depth h_o . (8)

Or

- (b) (i) A simple turbomachine is constructed from a disk with two internal ducts which exit tangentially through square holes, as in the Fig. 2. Water at 20°C enters the disk at the center, as shown. The disk must drive, at 250 rev/min, a small device whose retarding torque is 1.5 Nm. What is the proper mass flow of water, in kg/s? (8)

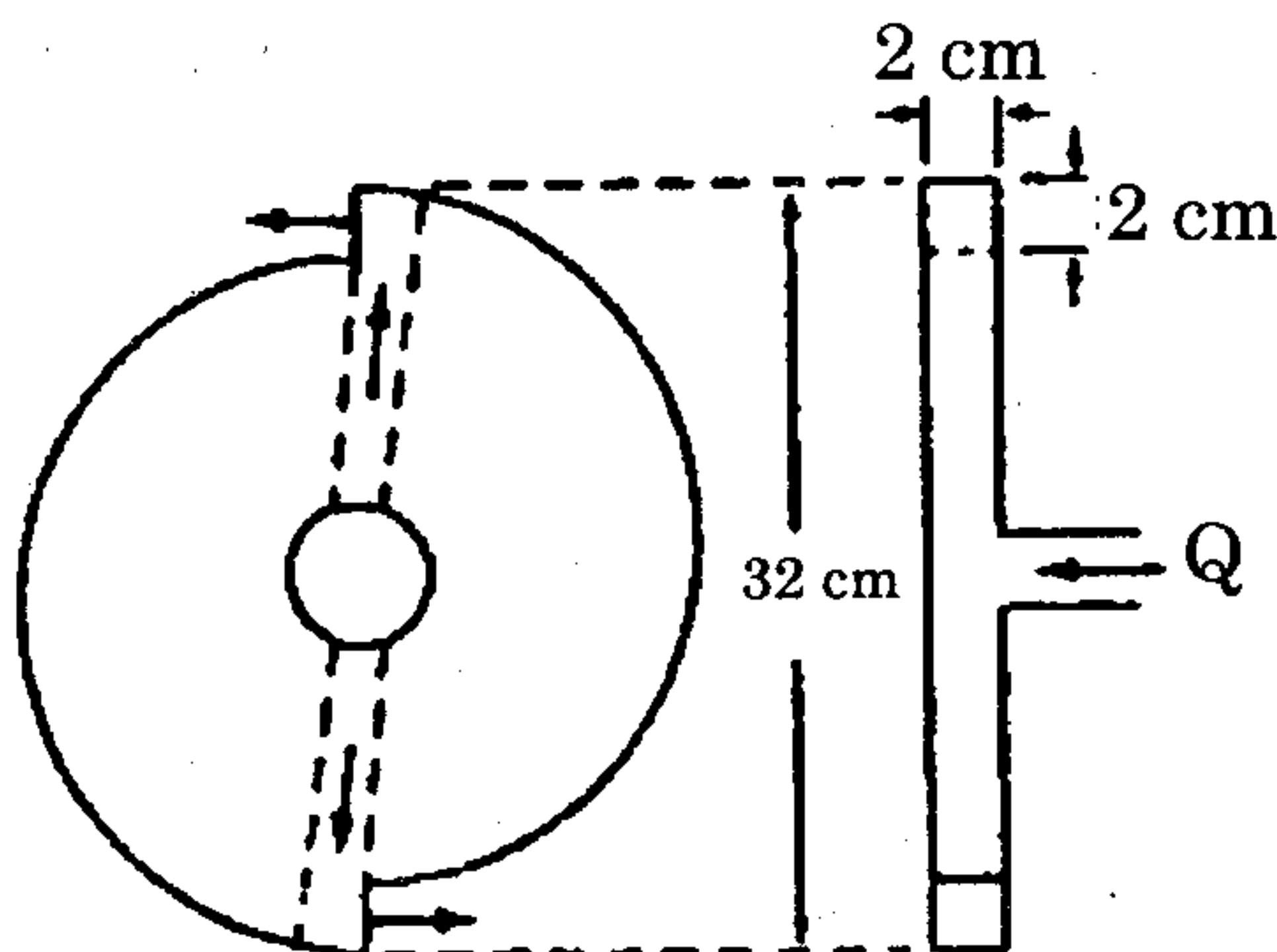

Fig. 2.

- (ii) A two-dimensional sheet of water, 10 cm thick and moving at 7 m/s, strikes a fixed wall inclined at 20° with respect to the jet direction. Assuming frictionless flow, find the normal force on the wall per meter of depth, and the widths of the sheet deflected upstream and downstream along the wall. (8)
12. (a) (i) Consider turbulent flow ($f = 0.184 \text{ Re}^{-0.2}$) of a fluid through a square channel with smooth surfaces. Now the mean velocity of the fluid is doubled. Determine the change in the head loss of the fluid. Assume the flow regime remains unchanged. What will be the head loss for fully turbulent flow in a rough pipe? (10)
- (ii) Discuss on various minor losses in pipe flow. (6)

Or

- (b) (i) Two tanks of fluid ($\rho = 998 \text{ kg/m}^3$ and $\mu = 0.001 \text{ kg/ms.}$) at 20°C are connected by a capillary tube 4 mm in diameter and 3.5 m long. The surface of tank 1 is 30 cm higher than the surface of tank 2. Estimate the flow rate in m^3/h . Is the flow laminar? For what tube diameter will Reynolds number be 500? (10)
- (ii) Explain the concept of boundary layer in pipes for both laminar and turbulent flows with neat sketches. (6)
13. (a) (i) Derive an expression for the shear stress at the pipe wall when an incompressible fluid flows through a pipe under pressure. Use dimensional analysis with the following significant parameters: pipe diameter D , flow velocity V , and viscosity μ and density ρ of the fluid. (10)
- (ii) Use dimensional analysis and the MLT system to arrange the following into a dimensionless number: L , ρ , μ and σ . (6)

Or

- (b) (i) Consider viscous flow over a very small object. Analysis of the equations of motion shows that the inertial terms are much smaller than viscous and pressure terms. Fluid density drops out, and these are called creeping flows. The only important parameters are velocity U , viscosity μ , and body length scale d . For three-dimensional bodies, like spheres, creeping flow analysis yields very good results. It is uncertain, however, if creeping flow applies to two-dimensional bodies, such as cylinders, since even though the diameter may be very small, the length of the cylinder is infinite. Let us see if dimensional analysis can help. (1) Apply the Pi theorem to two-dimensional drag force F_{2-D} as a function of the other parameters. Be careful: two-dimensional drag has dimensions of force per unit length, not simply force. (2) Is your analysis in part (1) physically plausible? If not, explain why not. (3) It turns out that fluid density ρ cannot be neglected in analysis of creeping flow over two dimensional bodies. Repeat the dimensional analysis, this time including ρ as a variable, and find the resulting non-dimensional relation between the parameters in this problem. (10)

- (ii) When fluid in a pipe is accelerated linearly from rest, it begins as laminar flow and then undergoes transition to turbulence at a time t_{tr} which depends upon the pipe diameter D , fluid acceleration a , density ρ and viscosity μ . Arrange this into a dimensionless relation between t_{tr} and D . (6)

14. (a) (i) A Kaplan turbine delivers 10 MW under a head of 25 m. The hub and tip diameters are 1.2 m and 3 m. Hydraulic and overall efficiencies are 0.90 and 0.85. If both velocity triangles are right angled triangles, determine the speed, guide blade-outlet angle and blade outlet angle. (10)

- (ii) Discuss - characteristics of centrifugal pump at constant speed. (6)

Or

- (b) (i) A centrifugal pump with an impeller diameter of 0.4 m runs at 1450 rpm. The angle at outlet of the backward curved vane is 25° with tangent. The flow velocity remains constant at 3 m/s. If the manometric efficiency is 84% determine the fraction of the kinetic energy at outlet recovered as static head. (10)

- (ii) Explain the load efficiency characteristics of hydraulic turbines with a diagram. (6)

15. (a) Discuss on the following: Working of double acting pump, indicator diagram, acceleration head, friction head. (16)

Or

- (b) With neat sketches, discuss about the rotary positive displacement pump. (16)