

L1B
27/12/13 AN

Reg. No. :

--	--	--	--	--	--	--	--	--	--	--	--	--	--	--	--	--	--	--	--

Question Paper Code : 31565

B.E./B.Tech. DEGREE EXAMINATION, NOVEMBER/DECEMBER 2013.

Fourth Semester

Mechanical Engineering

ME 2254/ME 45/CE 1259/10122 ME 405/080120018 — STRENGTH OF
MATERIALS

(Common to Production Engineering and Automobile Engineering)

(Regulation 2008/2010)

(Common to PTME 2254 – Strength of Materials for B.E. (Part-Time) Third
Semester Mechanical Engineering, Regulation 2009)

Time : Three hours

Maximum : 100 marks

Answer ALL questions.

PART A — (10 × 2 = 20 marks)

1. Define shear strain and volumetric strain.
2. What is meant by strain energy and proof resilience?
3. What are the types of beam and draw a neat sketch for each type?
4. Write down an equation for shear stress distribution across the cross section of a beam and draw a typical shear stress distribution diagram for an I-section.
5. Write down the equation of torsion showing the various terms involved in it.
6. A closely coiled helical spring is to carry a load of 500 N. Its mean coil diameter is to be 10 times that of the wire diameter. Calculate these diameters if the maximum shear stress in the material of the spring is to be 80 MN/m².
7. Write down the relationship between slope, deflection and radius of curvature.
8. Write down Euler's formula for calculating the critical load for a column (or) strut.

9. Calculate the thickness of metal required for a cast-iron main 800 mm in diameter for water at a pressure head of 100 m if the maximum permissible tensile stress is 20 MN/m^2 and weight density of water is 10 kN/m^3 .
10. What is meant by principal planes and principal stresses?

PART B — ($5 \times 16 = 80$ marks)

11. (a) Three bars made of copper, zinc and aluminium of equal length are rigidly connected at their ends as shown in Fig. (i)

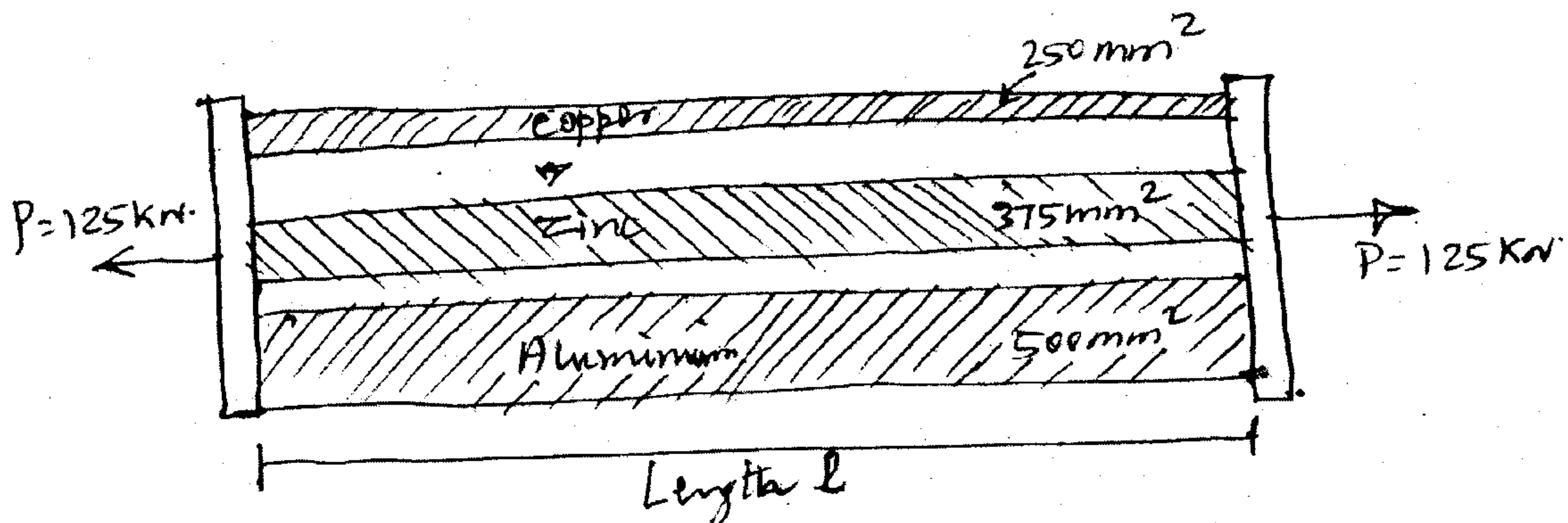

Fig. (i)

They have cross-sectional areas of 250 mm^2 , 375 mm^2 and 500 mm^2 respectively. If the compound member is subjected to a longitudinal pull of 125 kN , estimate the proportion of load carried on each rod and the induced stresses. Take $E_{\text{cu}} = 130 \text{ GN/m}^2$, $E_{\text{zn}} = 100 \text{ GN/m}^2$, $E_{\text{al}} = 80 \text{ GN/m}^2$. (16)

Or

- (b) The following data relate to a bar subjected to a tensile test :

Diameter of the bar = 30 mm

Tensile load $P = 54 \text{ kN}$

Gauge length $l = 300 \text{ mm}$

Extension of the bar $\delta_l = 0.112 \text{ mm}$

Change in diameter $\delta_d = 0.00366 \text{ mm}$

Calculate

(i) Poisson's ratio

(ii) The values of three moduli. (16)

12. (a) Draw the shear force and bending moment diagram for the simply supported beam shown in Fig. (ii). Clearly mark the position of the maximum bending moment and determine its value. (16)

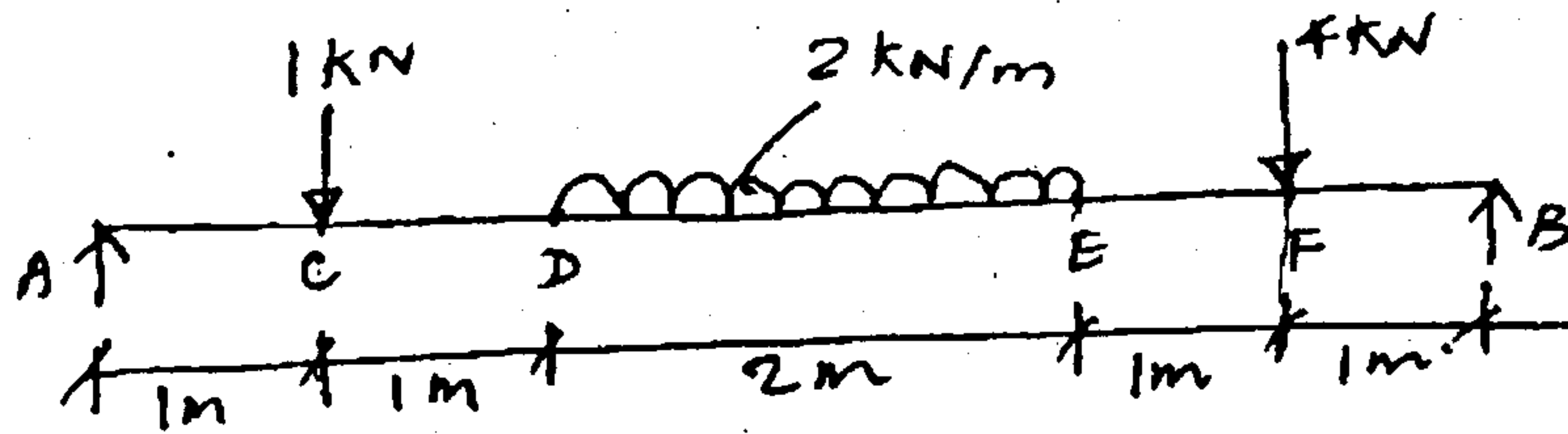

Fig. (ii)
Or

- (b) A steel bar 120 mm in diameter is completely encased in an aluminium tube of 180 mm outer diameter and 120 mm inner diameter so as to make it a composite beam. The composite beam is subjected to a bending moment of 15 kN-m. Determine the maximum stress in steel and aluminium due to bending. Take $E_s = 3E_{al}$. (16)
13. (a) A solid circular shaft transmits 75 kW power at 200 r.p.m. Calculate the shaft diameter, if the twist in the shaft is not to exceed 1° in 2 metres length of shaft, and shear stress is limited to 50 MN/m². Take $C = 100$ GN/m². (16)

Or

- (b) A closed coiled helical spring has stiffness of 10 N/mm; Its length when fully compressed with adjacent coils touching each other is 400 mm ; The modulus of rigidity of the material of the spring = 80 GPa.
- Determine the wire diameter and mean coil diameter if their ratio is 1/10.
 - If the gap between any two adjacent coil is 2 mm, what maximum load can be applied before the spring becomes solid (ie) adjacent coils touch.
 - What is the corresponding maximum shear stress in the spring? (16)
14. (a) A 2 meters long cantilever made up of steel tube of section 150 mm external diameter and 10 mm thick is loaded as in Fig. (iii)

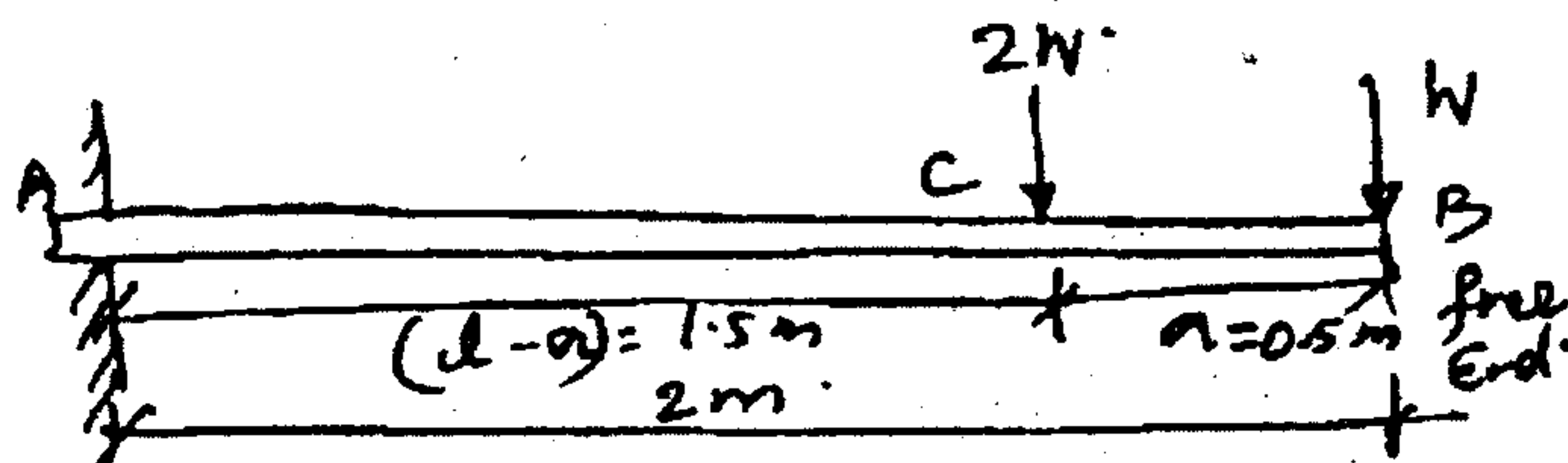
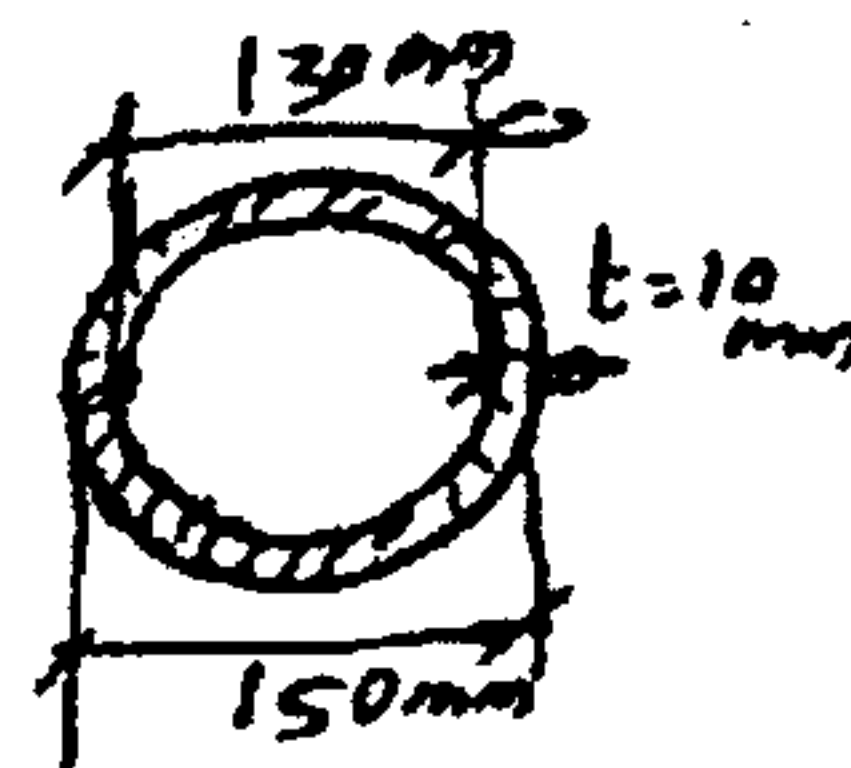

Fig. (iii)



Cross section of cantilever beam

If $E = 200 \text{ GPa}$ calculate

- (i) The value of W so that the maximum bending stress is 150 MPa
- (ii) The maximum deflection for the loading. (16)

Or

- (b) A bar of length 4 m when used as a simply supported beam and subjected to a u.d.l. of 30 kN/m over the whole span, deflects 15 mm at the centre. Determine the crippling load when it is used as a column with following end conditions.
 - (i) both ends pin - jointed (5)
 - (ii) one end fixed and the other end hinged (6)
 - (iii) both ends fixed. (5)
15. (a) An element in a stressed material has tensile stress of 500 MPa and a compressive stress of 350 MPa acting on two mutually perpendicular planes and equal shear stresses of 100 MPa on these planes. Find principal stresses and position of the principal planes. Find also maximum shearing stress. (16)

Or

- (b) A boiler shell is to be made of 15 mm thick plate having tensile stress of 120 MPa . If the efficiencies of the longitudinal and circumferential joints are 70% and 30% respectively, determine :
 - (i) Maximum permissible diameter of the shell for an internal pressure of 2 MPa
 - (ii) Permissible intensity of internal pressure when the shell diameter is 1.5 m . (16)