

LIB
14/12/13 AN

Reg. No. :

--	--	--	--	--	--	--	--	--	--	--	--	--	--	--	--	--	--	--	--

Question Paper Code : 31350

B.E./B.Tech. DEGREE EXAMINATION, NOVEMBER/DECEMBER 2013.

Second Semester

Electronics and Communication Engineering

EC 2151/EC 25/10144 EC 205/080290007/EE 1152 — ELECTRIC CIRCUITS AND
ELECTRON DEVICES

(Common to Computer Science and Engineering, Biomedical Engineering, Medical
Electronics Engineering and Information Technology)

(Regulation 2008/2010)

Time : Three hours

Maximum : 100 marks

Answer ALL questions.

PART A — (10 × 2 = 20 marks)

1. State Kirchoffs current and voltage laws.
2. State superposition theorem.
3. Define Q factor of series resonant circuit.
4. Draw frequency response of R-L network.
5. Draw energy band diagram of semiconductor.
6. Define diffusion capacitance.
7. Draw input characteristics of CB transistor.
8. Define drain to source resistance of JFET.
9. What is LED?
10. Write the principle of operation of photodiode.

PART B — (5 × 16 = 80 marks)

11. (a) Find the value R so that 1A current would flow in it, for the network in the figure shown below. (16)

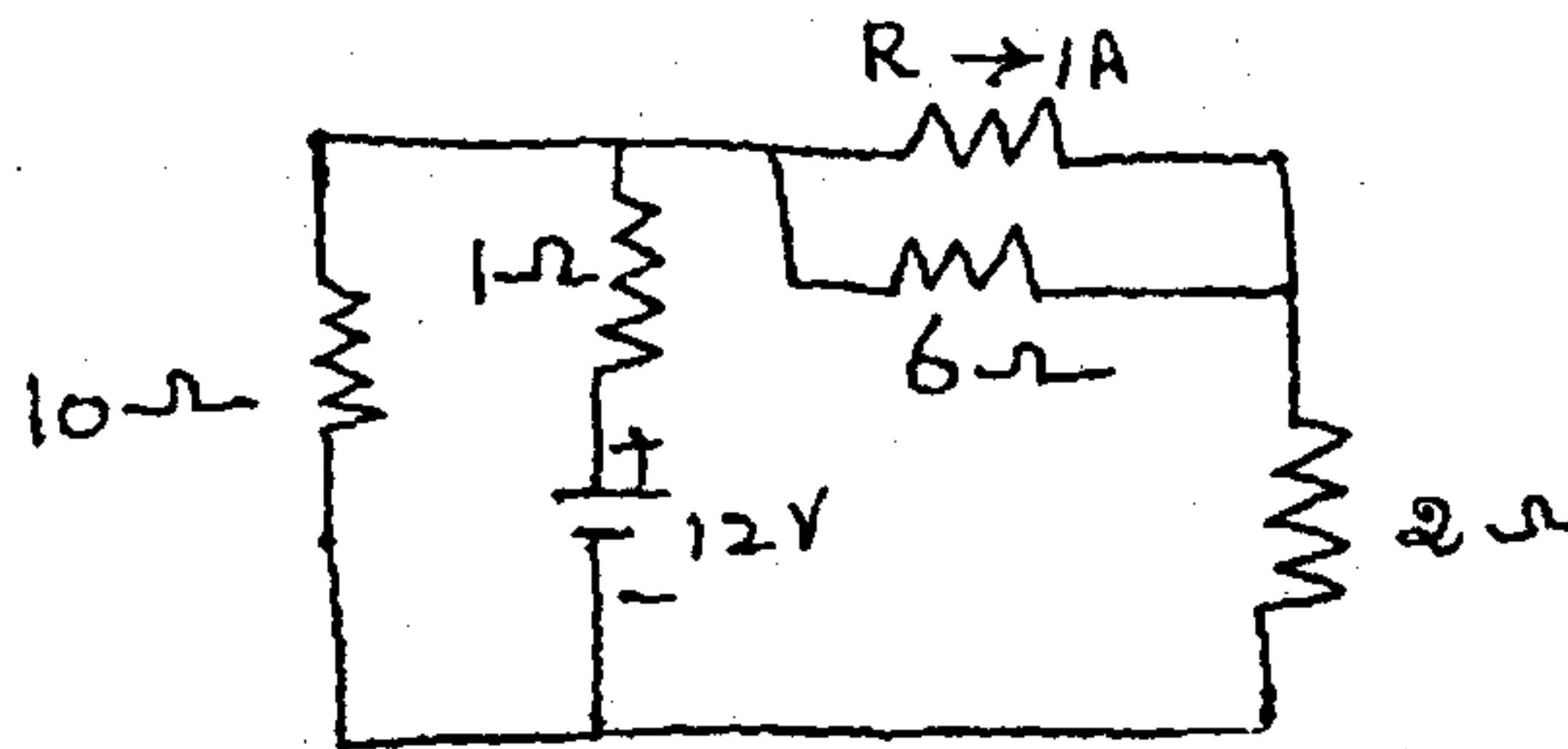

Or

- (b) State Norton's theorem and find the current through branch b-e using Norton's theorem. (16)

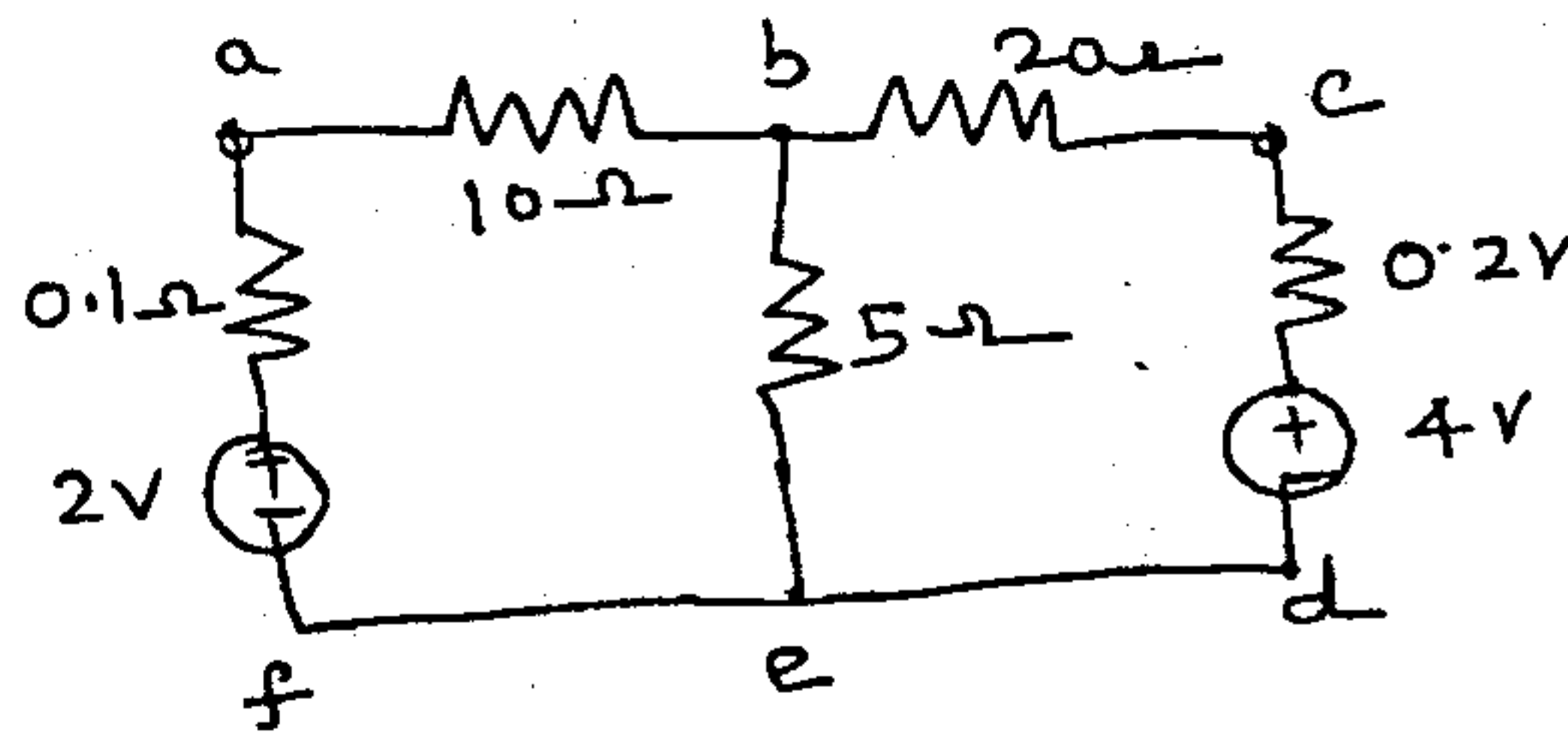

12. (a) Obtain expression for the instantaneous current through the RLC series circuit with sinusoidal input. (16)

Or

- (b) What is Q factor? Find value of Q factor for an inductor and capacitor, connected in series. (16)

13. (a) Draw and explain zener diode and its characteristics. (16)

Or

- (b) What is transition capacitance and obtain expression for transition capacitance in PN junction diode. (16)

14. (a) Explain with neat diagram the operation of NPN transistor. (16)

Or

- (b) Describe construction and operation of n-channel depletion type MOSFET. (16)

15. (a) (i) With a neat sketch explain construction and VI characteristics of tunnel diode. (10)
- (ii) Explain construction and operation of photoconductive cell. (6)

Or

- (b) (i) Draw and describe the principle of operation and characteristics of SCR. (8)
- (ii) Draw and explain the working and characteristics of UJT. (8)
-