

Reg. No. :

--	--	--	--	--	--	--	--	--	--

Question Paper Code: 44501

B.E. / B.Tech. DEGREE EXAMINATION, DEC 2020

Fourth Semester

Electronics and Instrumentation Engineering

14UEI401 - CONTROL ENGINEERING

(Regulation 2014)

Duration: One hour

Maximum: 30 Marks

PART A - (6 x 1 = 6 Marks)

(Answer any six of the following questions)

- Which of the following system is not an example of closed loop system?
 - Traffic light controller
 - Action of human being in walking
 - Home heating system
 - DC motor speed control
- In force-voltage analogy, spring constant is analogous to
 - Voltage
 - Reciprocal of capacitance
 - Capacitance
 - Charge
- State the order and type number of the system for the given open loop transfer function
$$G(s) = \frac{10}{s(1 + 0.4s)(1 + 0.1s)}$$
 - 0, 3
 - 1, 3
 - 3, 2
 - 3, 1
- Which of the following characteristics does it have, the given closed loop transfer function
$$\frac{C(s)}{R(s)} = \frac{121}{s^2 + 132s + 121}$$
 of a system
 - Over damped system and setting time 1.1s
 - Under damped system and setting time 0.6s
 - Critically damped system and setting time 0.8s
 - Under damped system and setting time 0.707s

5. Phase margin of a system is used to specify which of the following?
 (a) Frequency response (b) Absolute stability
 (c) Relative stability (d) Time response
6. At the gain cross over frequency, $\omega=5$ rad/s, $\angle G(j\omega)H(j\omega) = -170^\circ$. The phase margin is
 (a) -10° (b) 10° (c) -170° (d) 170°
7. If the poles of a system lie on the imaginary axis, the system will be
 (a) stable (b) unstable
 (c) marginally stable (d) Conditionally stable
8. Normal Routh array indicates
 (a) non zero elements in the first column (b) row of all zeros
 (c) first column element of the row is zero (d) row of all ones
9. Number of _____ in a state diagram of discrete time system is equal to number of state variables.
 (a) integrators (b) state variables
 (c) phase variables (d) unit delay
10. The state variable approach is applicable to
 (a) Only linear time in-variant systems
 (b) Linear time in-variant as well as time varying systems
 (c) Linear as well as non linear systems
 (d) All type of systems

PART – B (3 x 8= 24 Marks)

(Answer any three of the following questions)

11. For the electrical circuit in figure-1, Find the transfer function $\frac{V_{out}(s)}{V_{in}(s)}$ (8)

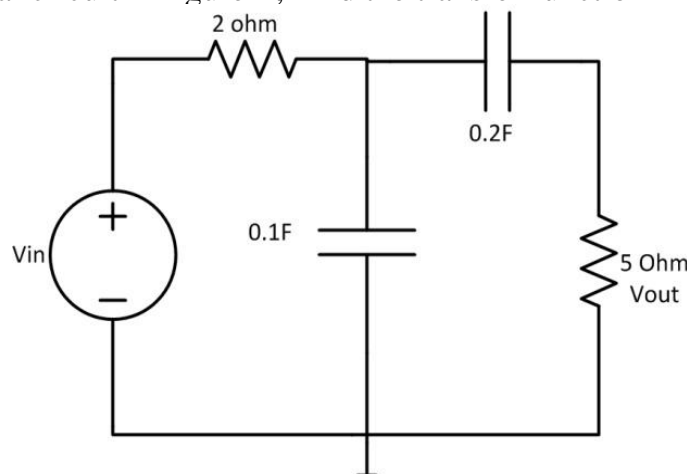

12. Consider a unity feedback system with a closed loop transfer function $C(s)/R(s) = (Ks+b)/(s^2+as+b)$. Determine the open loop transfer function $G(s)$. Show that the steady state error with unit ramp input is given by $(a-k)/b$. (8)
13. Explain the design procedure involved in the design of lag compensator. (8)
14. Determine the stability of a system, whose characteristics equation is given by $s^6 + 2s^5 + 8s^4 + 12s^3 + 20s^2 + 16s + 16 = 0$. Also find the number of roots lying in the LHS, RHS and imaginary axis of s-plane. (8)
15. Determine whether the system is completely controllable and observable

$$A = \begin{bmatrix} 0 & 0 & 1 \\ -2 & -3 & 0 \\ 0 & 2 & -3 \end{bmatrix}; B = \begin{bmatrix} 0 \\ 2 \\ 0 \end{bmatrix}; C = [1 \ 0 \ 0].$$
 (8)