

Reg. No. :

--	--	--	--	--	--	--	--	--	--	--

Question Paper Code: 35302

B.E. / B.Tech. DEGREE EXAMINATION, APRIL 2019

Fifth Semester

Electrical and Electronics Engineering

01UEE502 - CONTROL SYSTEMS

(Regulation 2013)

Duration: Three hours

Maximum: 100 Marks

Answer ALL Questions

PART A - (10 x 2 = 20 Marks)

1. Differentiate open loop and closed loop control systems with examples.
2. Define mathematical model of the system.
3. List the time domain specifications.
4. Write the transfer function of PID controller.
5. What is phase and gain cross-over frequency?
6. Name the parameters which constitute the frequency domain specifications.
7. Define stability of a system.
8. What is Nyquist stability criterion?
9. What are the properties of state transition matrix?
10. Define controllability.

PART - B (5 x 16 = 80 Marks)

11. (a) (i) Explain the open loop and closed loop system with an example. (8)
 (ii) Explain the working principle of AC Servomotor. (8)

Or

- (b) Using block diagram reduction technique find the closed loop transfer function of the system whose block diagram is shown in figure. (16)

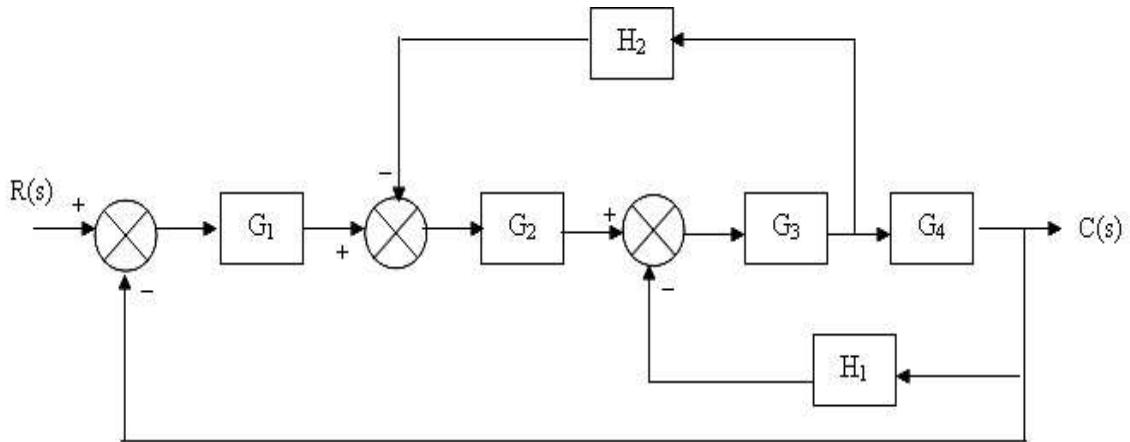

12. (a) The open loop transfer function of a servo system with unity feedback is $G(s) = \frac{10}{s(0.1s + 1)}$. Evaluate the static error constants of the system. Obtain the Steady state error of the system, when subjected to an input given by the polynomial, $r(t) = a_0 + a_1t + \frac{a_2}{2}t^2$. (16)

Or

- (b) Sketch the root locus of the system whose open loop transfer function is $G(S) = \frac{K}{S(S + 2)(S + 4)}$. Find the value of K so that the damping ratio of the closed loop system is 0.5. (16)

13. (a) Sketch Bode plot for the following transfer function and determine the gain and phase cross over frequencies.

$$G(s) = \frac{10}{s(1 + 0.4s)(1 + 0.1s)} \quad (16)$$

Or

(b) Consider a unity feedback system having an open loop transfer function

$$G(S) = \frac{K}{S(1 + 0.2S)(1 + 0.05S)}. \text{ Sketch the polar plot and determine the value of } K$$

so that (i) Gain margin is 18 db (ii) Phase margin is 60 deg.

14. (a) Use the routh stability criterion to determine the location of roots on the s-plane and hence the stability for the system represented by the characteristic equation

$$s^5 + 4s^4 + 8s^3 + 8s^2 + 7s + 4 = 0. \quad (16)$$

Or

(b) Determine the nyquist plot for the system whose open loop transfer function is,

$$G(S)H(S) = \frac{K}{S(S+2)(S+10)}. \text{ Determine the range of } K \text{ for which closed loop}$$

system is stable. (16)

15. (a) The transfer function of a control system is given by $\frac{Y(S)}{U(S)} = \frac{(S+2)}{(S^3 + 9S^2 + 26S + 4)}$

Check For Controllability. (16)

Or

(b) A linear time-invariant system is characterized by homogeneous state equation.

$$\begin{bmatrix} \dot{x}_1 \\ \dot{x}_2 \end{bmatrix} = \begin{bmatrix} 1 & 0 \\ 1 & 1 \end{bmatrix} \begin{bmatrix} x_1 \\ x_2 \end{bmatrix}. \text{ Compute the solution of the homogeneous equation, assuming}$$

the initial state vector, $X_0 = \begin{bmatrix} 1 \\ 0 \end{bmatrix}$. (16)

