

Reg. No. :

--	--	--	--	--	--	--	--	--	--

Question Paper Code: 47104

B.E. / B.Tech. DEGREE EXAMINATION, APRIL 2019

Seventh Semester

Civil Engineering

14UCE704 - STRUCTURAL DYNAMICS AND EARTHQUAKE ENGINEERING

(Note: Use of IS 13920:1993, IS 4326:1993 and IS 1893(Part 1):2002 are permitted in the End Semester Examinations)

(Regulation 2014)

Duration: Three hours

Maximum: 100 Marks

Answer ALL Questions

PART A - (10 x 1 = 10 Marks)

1. The equation of motion is just another form of

(a) Newton's second law of motion

(b) Newton's first law

(c) Newton's third law

(d) None of the above

2. Natural frequency of suspended frequency is

(a) $\omega_n = \sqrt{\frac{k}{m}}$

(b) $\omega_n = \sqrt{\frac{m}{k}}$

(c) $\omega_n = \sqrt{\frac{1}{km}}$

(d) None of the above

3. The graphical representations of the relative amplitude of the two co-ordinates and their phase angle relationship is called as

(a) Bending moment diagram

(b) Mohr's diagram

(c) Mode shape diagram

(d) Shear force diagram

4. The mode corresponding to the lowest frequency is called as
 - (a) Fundamental mode
 - (b) Third mode
 - (c) Second mode
 - (d) None of the above
5. The movements of plates towards each other and collide
 - (a) Divergent boundary
 - (b) Convergent boundary
 - (c) Transform boundary
 - (d) Plate boundary
6. For an ideal Rigid building, Time Period is
 - (a) greater than one
 - (b) less than zero
 - (c) greater than zero
 - (d) equal to zero
7. Response spectrum represents by :
 - (a) IS 1839 : 2002
 - (b) IS 1893 : 2001
 - (c) IS 1839 : 2001
 - (d) IS 1893 : 2002
8. The ratio between ultimate deformation to initial yielding
 - (a) Dilation factor
 - (b) Moment distribution
 - (c) Ductility factor
 - (d) Damping factor
9. The formula for design base shear (V_b) is
 - (a) $A_h W$
 - (b) $A_h W/4$
 - (c) $A_h W/3$
 - (d) $A_h W/2$
10. Stress strain curve for a complete cycle of loading and unloading is known as
 - (a) pinching
 - (b) bauschinger
 - (c) hysteresis loop
 - (d) none of these

PART - B (5 x 2 = 10 Marks)

11. State D' Alembert's principle.
12. Distinguish between undammed and damped vibrations.
13. What are the causes of Earthquake?
14. What is bouchinger effect?
15. What is the need of ductility?

PART - C (5 x 16 = 80 Marks)

16. (a) Derive the equation of motion for single degree of freedom with free vibration by following methods: (16)

(a) D Alembert's principle

(b) Energy methods.

Or

(b) Find the natural frequency of the system as shown in Figure 1.1. Take $k_1 = k_2 = 1500 \text{ N/m}$, $k_3 = 2000 \text{ N/m}$ and mass ' m ' = 10kg. (16)

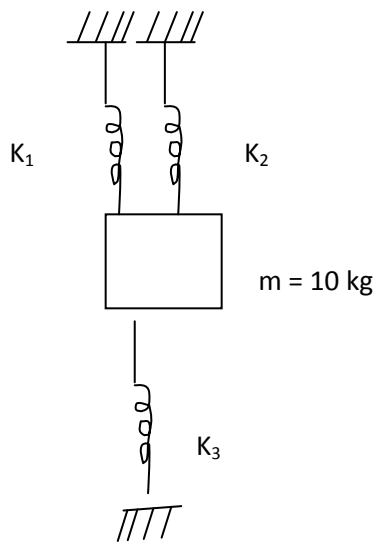

Figure : 1.1

17. (a) The two story shear frame with combined stiffness of ground and first floor columns are 200 kN/m and 100 kN/m respectively. Mass of the each floor is 2000 kg. Determine the natural frequencies of and mode shapes. (16)

Or

(b) An undamped single degree of freedom system ($m = 30 \text{ kg}$, $k = 500 \text{ N/m}$) is given an initial displacement of 10 mm and initial velocity of 75 mm/s. Find (16)

(a) The natural frequency

(b) The period of vibration

(c) The amplitude of motion

(d) The time at which the second and third maximum peak occurs.

18. (a) Explain in detail about the behavior of RCC, Steel and prestressed concrete Structures under earthquake loading. (16)

Or

(b) (i) Explain in detail about “Elastic Rebound Theory”. (8)

(ii) Discuss the structural systems for RC buildings for carrying vertical loads and lateral loads with neat sketches. What is the most desirable configuration of lateral load resisting elements? (8)

19. (a) (i) Explain in detail about the irregularity in configurations of buildings with respect to earthquake resistant structural system. (8)

(ii) Explain about base isolation techniques with neat sketch. (8)

Or

(b) (i) Explain design spectrum. And how it's differs from response spectra? (8)

(ii) Explain the concept of design? (8)

20. (a) (i) Explain the Guidelines given by IS 4326– 1993 for Earthquake resistant design. (8)

(ii) Explain in detail, how do you calculate the base shear in a building with zone factor and importance factor? (8)

Or

(b) (i) Write note “Strong column – weak beam concept”. (8)

(ii) Explain methods to determine the earthquake force in various members of building once the base shear has been determined. (8)